



TRUCONNECT® API

An easy solution to connect equipment data insights in your way



What is an API?

Application Programmable Interface (API) provides a standard and secure way for different applications to connect and work with each other and deliver the requested information without user intervention.

EQUIPMENT DATA YOUR WAY

Konecranes Cloud APIs allow customers to fetch TRUCONNECT® (or other) relevant data into their own systems through a secure cloud. TRUCONNECT® API can fetch equipment usage and performance data as well as other relevant KPI indicators for a clearer picture of your operations, improved maintenance and equipment uptime.

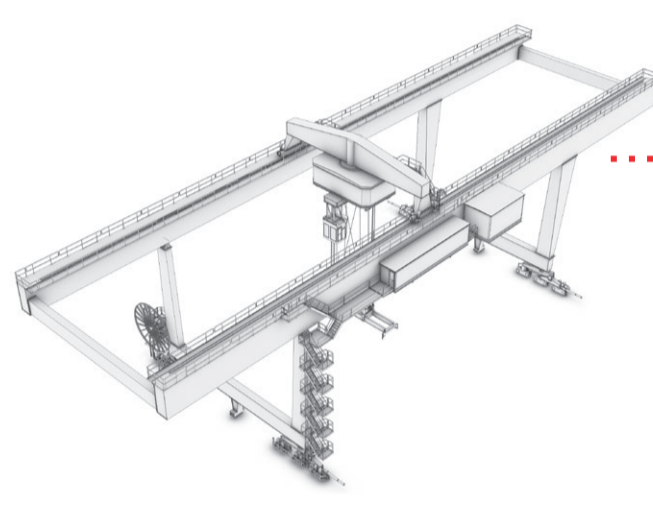
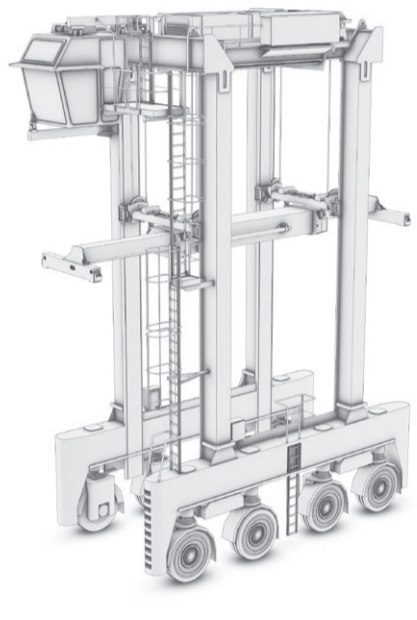
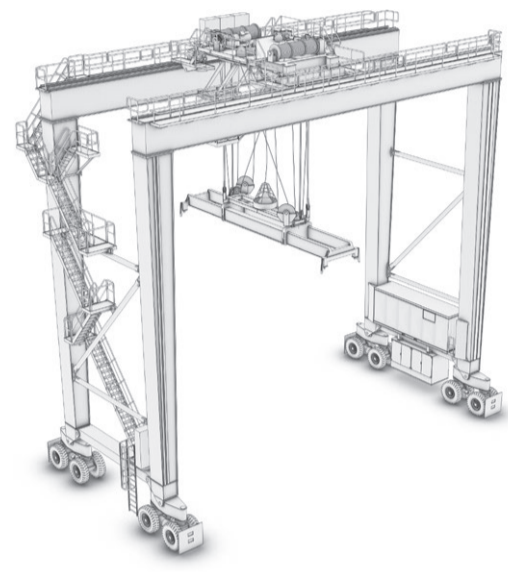

Works across any Konecranes equipment with TRUCONNECT®.

RTG

Rubber-Tyred Gantry

RMG

Rail-Mounted Gantry

STS

Ship-to-Shore

MHC

Mobile Harbour Crane

LT

Lift Truck

SC

Straddle Carrier

PROBLEM

- Logging in to multiple OEM portals and other platforms to seek relevant equipment data
- Manually tracking basic data directly from the crane (e.g., running hours)
- Manually copying data from multiple places to a central CMMS/EAM/ERP system

SOLUTION

Standardized API (ISO 15143-3:2020 compliant) of asset TRUCONNECT data integrated to any capable customer system (e.g., CMMS/EAM/TOS/ERP)

- Includes a Basic or Premium set of data packages, automatically tracking a defined set of actionable data
- Data can be automatically fetched into your own systems for an automated flow for data-based triggers within the system (e.g., service requests/work orders based on set data intervals/condition)

BENEFITS

- **Automated:** APIs allow technicians to by-pass manual checking. Service requests or work orders can be triggered by pre-defined or critical asset data automatically
- **Efficient:** APIs provide reliable results, no need to manually input values from assets as the values are added directly into customer's systems
- **Flexible:** This back-end system works with any existing front-end system
- **Integrated:** Our APIs integrate across all TOS/ERP/CMMS/EAM systems, delivering your equipment data to you, in whichever way you need
- Awarded ISO/IEC 27001 certification for information security management



HOW TO GET STARTED

1. Register for free at the Konecranes API management platform
2. Login and test the API and view all relevant documents
3. Subscribe to any of the TRUCONNECT® API data packages applicable to your asset
4. Receive your dedicated Client ID and Client Secret
5. Use these access details to start using the API immediately to authorize, fetch and track equipment data
6. Access the developer portal containing relevant documentation support and testing setup to assist with API testing and adoption
7. Further additional support provided by Konecranes

WHAT YOU NEED TO KNOW

- Your equipment requires TRUCONNECT® system installed to allow data flow through the cloud
- Equipment requires working connectivity
- Requires equipment API subscription

