



HOW DO crickets detect danger?

They have evolved small hairs that can **detect** the air current of a nearby frog opening its mouth.

Safety-Assist Retrofits

Laser- and sensor-based crane adaptations allowing operators to detect dangerous situations.

Safety. Evolved.



ADAPT AND THRIVE

Konecranes is the premier **port services** provider to brownfield terminal developments. Our range of retrofit products will enable your fleet to adapt to a fast-changing environment. Welcome to your **evolution**.

Small, incremental changes that enable existing fleets to continue to adapt and thrive.

Fire Suppression System

Automatically detect and extinguish critical area fires.

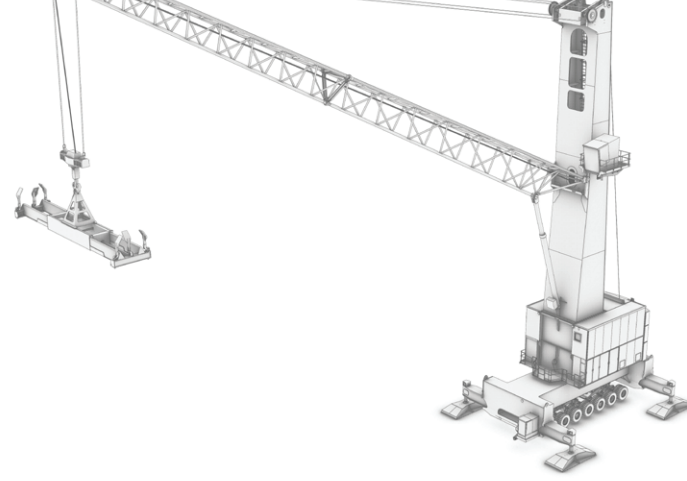
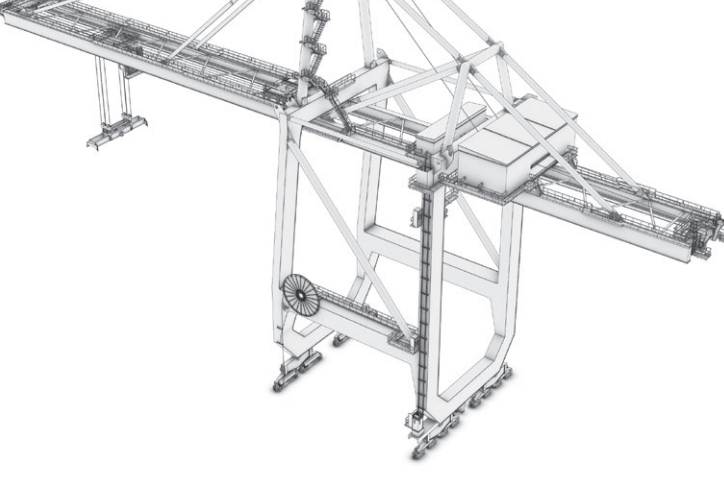
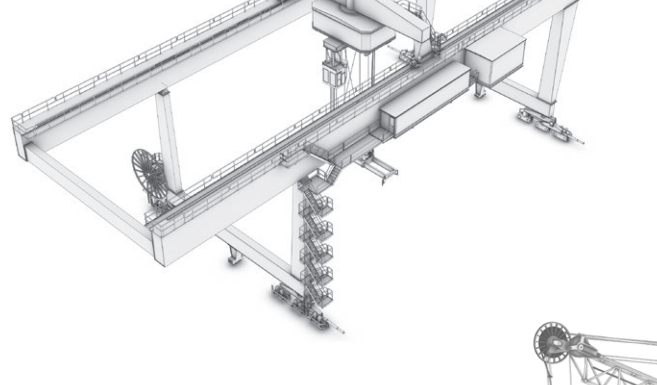
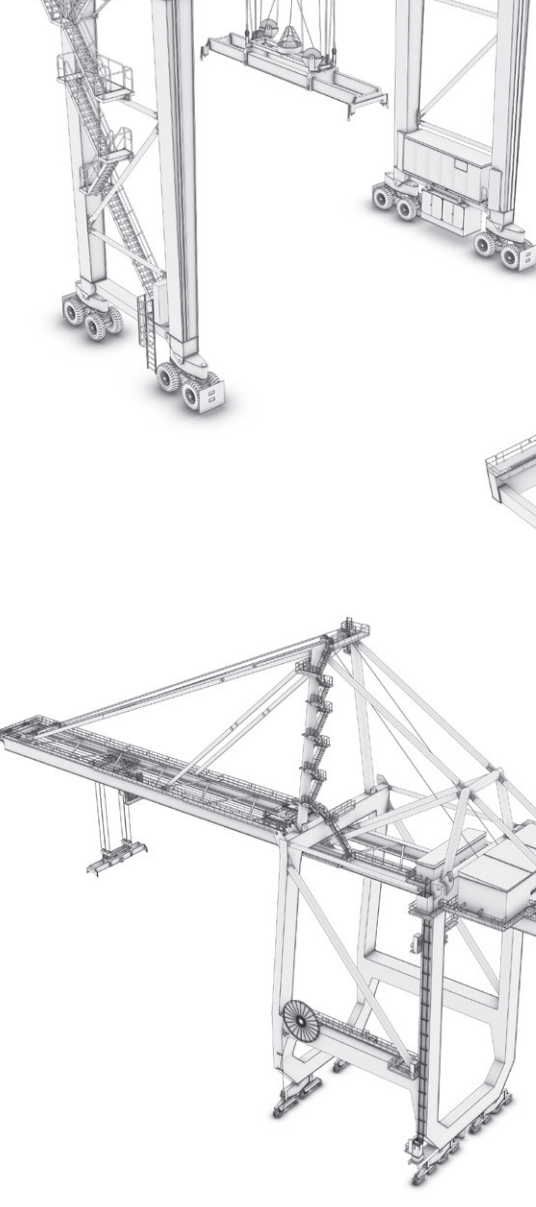
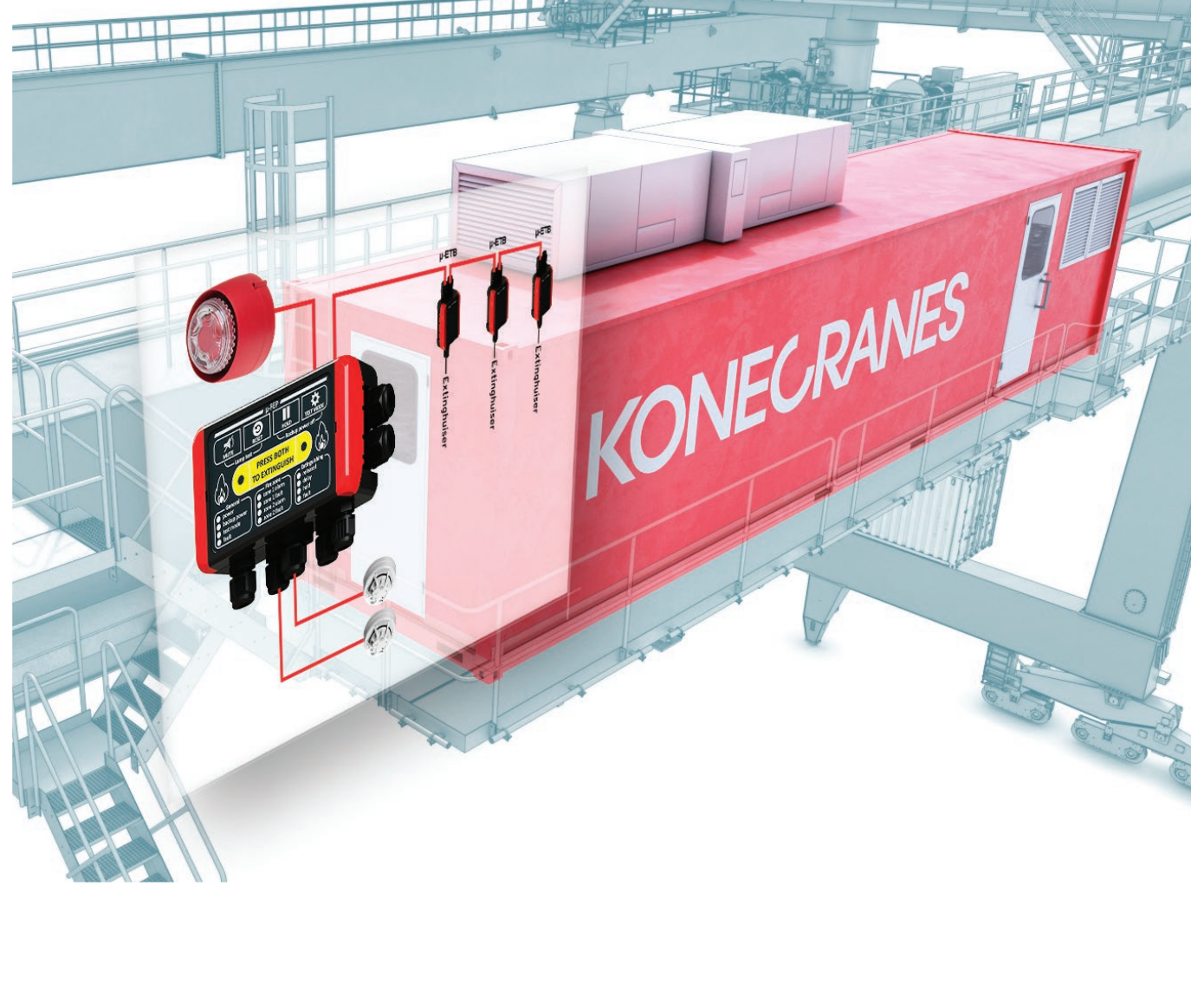

EQUIPMENT

This system can be applied to the following equipment, **including other crane brands.**

AB

Any Brand

RTG

Rubber-Tyred Gantry

STS/GU

Ship-to-Shore Grab Unloader

RMG

Rail-Mounted Gantry

MHC

Mobile Harbor Crane

SYC

Ship Yard Crane (case by case)



BENEFITS

- Aerosol units are not pressurized or toxic
- No expensive pipe work required
- Can easily be connected to conventional/existing fire detection systems
- Can be installed inside engine and generator rooms, limiting fire spread
- Fully automatic and autonomous system of activation
- Backup power supply via UPS
- Can be used in places with an ambient temperature ranging from -50°C to +75°C with humidity up to 98%.
- Use a unique cooling system preventing any form of efficiency loss.
- Require far less maintenance compared to other conventional systems.
- Aerosol is not harmful to humans or animals.

HOW IT WORKS

Control: Each protected area has its own control panel. The panel can test, program and control alarms and extinguishers.

Detection: Detectors are smoke and heat detecting. There is also the option, for diesel generators, for an entirely mechanical Thermocord detection option.

Alarm: The system includes siren and visual alarms located in highly visible areas of the crane. Immediate shut-down function is also hardwired to the stop function of the crane.

Suppression: Aerosol generators are automatically triggered by the sensors, and emit a non-toxic cloud of fire suppressant. The generators are guaranteed for a serviceable lifetime of 15 years.



WHAT YOU NEED TO KNOW

- The system is designed according to your equipment, cycle-times and port-specific protocols
- Crane would need to be available to installation team at a safe work area on site.

SELECTED REFERENCES



Year	Customer/Location	Quantity
2021	C. Steinweg / Al Liwa	3
2019	GSEZ / Valencia	2

Ports. Evolved.

KONECRANES®



Konecranes is a world-leading group of Lifting Businesses™, serving a broad range of customers, including manufacturing and process industries, shipyards, ports and terminals. Konecranes provides productivity enhancing lifting solutions as well as services for lifting equipment of all makes. The Group has more than 16,000 employees at 600 locations in 50 countries. Konecranes shares are listed on the Nasdaq Helsinki (symbol: KCR).

© 2021 Konecranes. All rights reserved. 'Konecranes', 'Lifting Businesses' and 'C' are either registered trademarks or trademarks of Konecranes.

This publication is for general informational purposes only. Konecranes reserves the right at any time, without notice, to alter or discontinue the products and/or specifications referenced herein. This publication creates no warranty on the part of Konecranes, express or implied, including but not limited to any implied warranty or merchantability or fitness for a particular purpose.