

How do crickets detect danger?

They have evolved small hairs that can detect the air current of a nearby frog opening its mouth.



Safety. Evolved.

Safety-Assist Retrofits

Crane adaptations that detect danger and enable safer operations.

Stack Collision Prevention

Assists operators to lift, lower and place containers with a higher degree of safety and accuracy.



Watch video at this link

Adapt and thrive

Konecranes is the premier port services provider to brownfield terminal developments. Our range of retrofit products will enable your fleet to adapt to a fast-changing environment. Welcome to your evolution.

Benefits

- Prevents container collisions and knock-downs as the trolley moves towards the bay
- Prevents unsafe loading in the mixed bays
- Works with both loaded and empty spreaders
- Allows for fine positioning
- Operator can navigate container in bad weather and around stacks of uneven height
- Easy to use and maintain: only uses electrical components so only sensor cleaning is required.



AB
Any Brand

This technology can be applied to the following Konecranes equipment and any other crane brand. Installation of laser sensor and PLC connection may vary when implementing system to other brands.

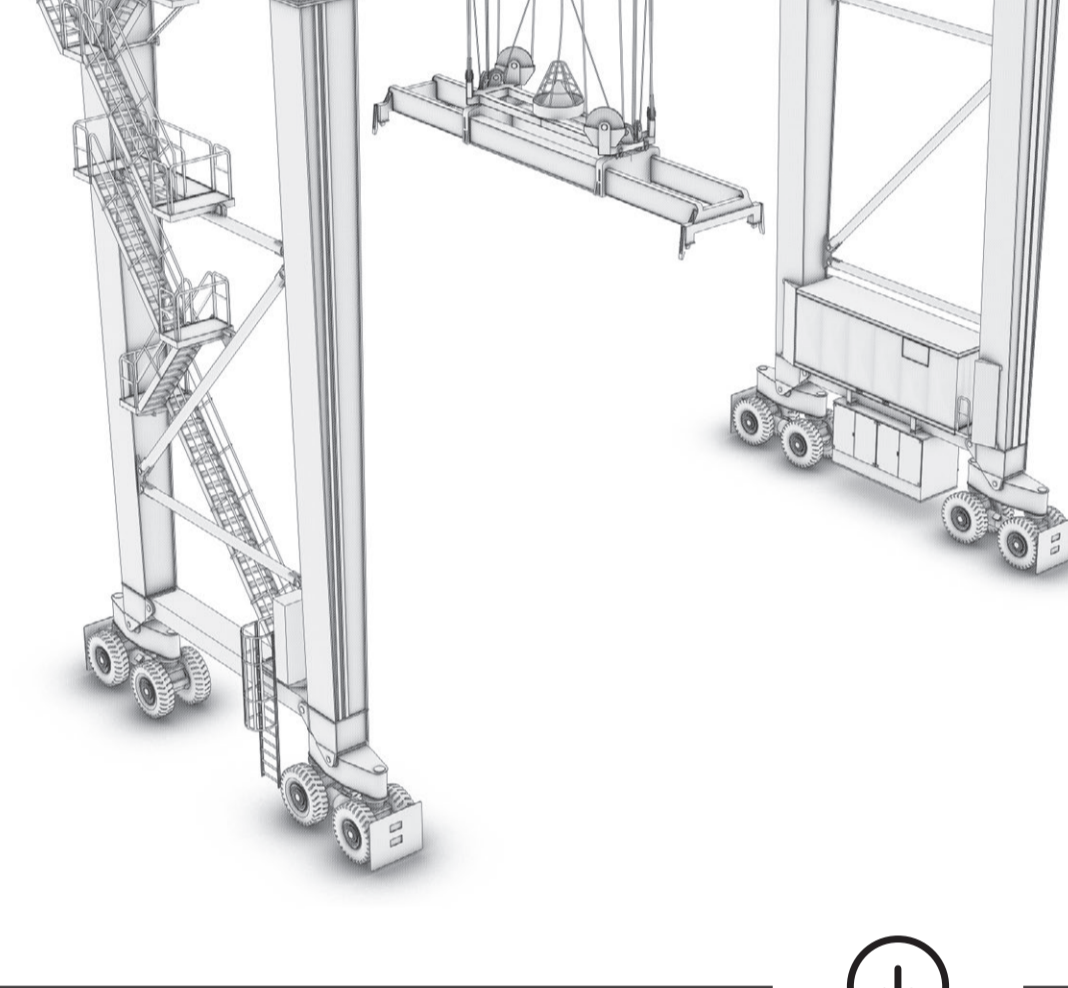

RTG
Rubber-Tired Gantry Crane

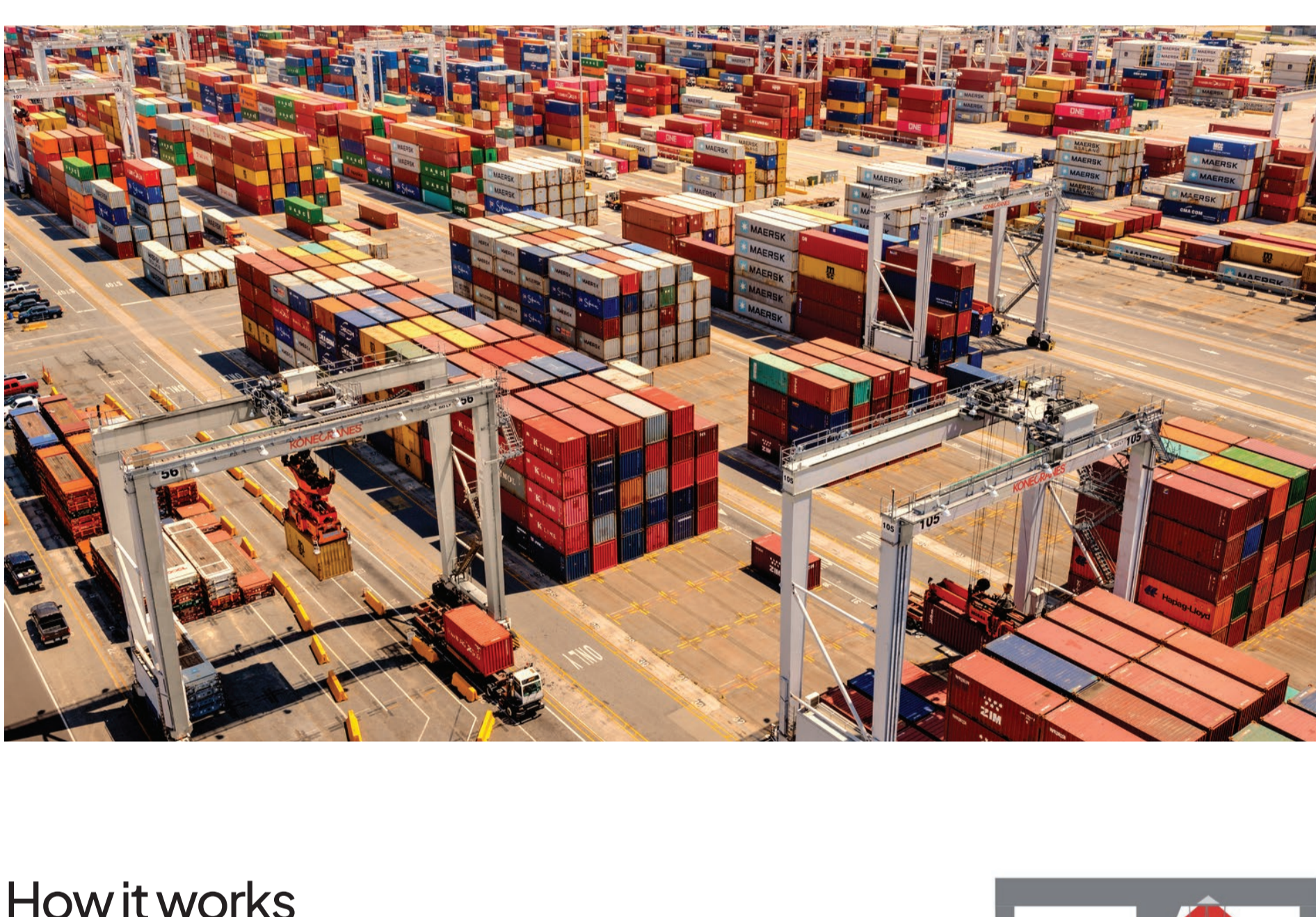

How it works

- Two laser scanners constantly check the running bay when the trolley is in motion
- Trolley movement is free until the hoist moves below a predefined safe zone
- If an obstacle appears in one of the pre-programmed safety zones, the crane's PLC decreases the speed of the trolley towards the obstacle
- The system also detects both 20-foot and 40-foot containers in the same bay
- For increased safety, both laser scanners operate independently.

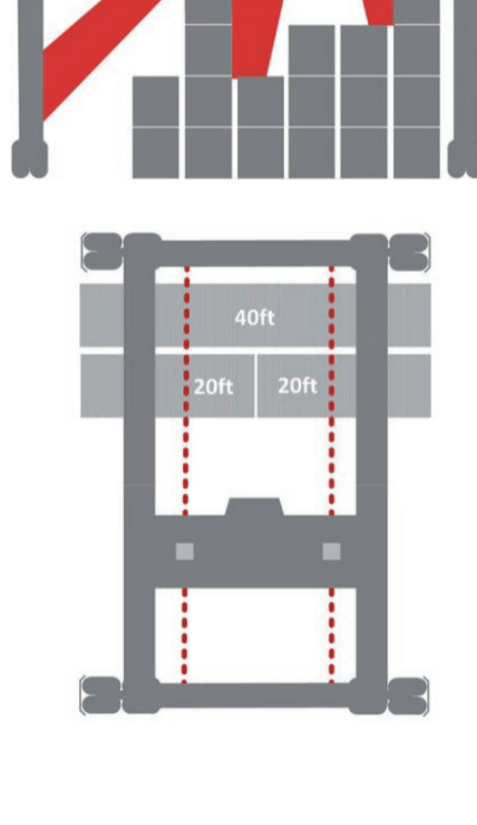

What you need to know

- The system cannot monitor the container stack profiles of adjacent bays
- Stack collision prevention is a mandatory step in the conversion to remote operation
- Turn-key project delivery with all required hardware and software plus training
- Site works and commissioning: 2 days per crane
- Customer needs to ensure prompt availability of cranes to ensure the above timelines
- Customer needs to provide safe location where installation and commissioning can be completed.



Selected References



YEAR	CUSTOMER/LOCATION	QUANTITY
2020	Gemalink / Cai Mep	18
2020	MSC / Valencia	7
2020	PHA / Houston	17
2016	APC / Ashdod	24

Ports. Evolved.



Konecranes is a global leader in material handling solutions, serving a broad range of customers across multiple industries. We consistently set the industry benchmark, from everyday improvements to the breakthroughs at moments that matter most, because we know we can always find a safer, more productive and a better way. That's why, with around 16,600 cranes in over 50 countries, Konecranes is trusted every day to lift, handle and move what the world needs. In 2023, Group sales totalled EUR 4.0 billion. Konecranes shares are listed on Nasdaq Helsinki (symbol: KCR).

© 2024 Konecranes. All rights reserved. 'Konecranes', 'Moves what matters' and are either registered trademarks or trademarks of Konecranes.
This publication is for general informational purposes only. Konecranes reserves the right at any time, without notice, to alter or discontinue the products and/or specifications referenced herein. This publication creates no warranty on the part of Konecranes, express or implied, including but not limited to any implied warranty or merchantability or fitness for a particular purpose.