

[contact us](#)

How do

Indigo Buntings locate the same acre of land every summer?

They calculate their position using the stars.



Positioning. Evolved.

Auto-Truck Guiding Retrofit

Accurate truck positioning for faster truck handling and improved yard safety.



Watch video at this link

Adapt and thrive

Konecranes is the premier port services provider to brownfield terminal developments. Our range of retrofit products will enable your fleet to adapt to a fast-changing environment. Welcome to your evolution.



Benefits

- RTG can pick up or place container with minimum movement
- Reduced truck handling times
- Safer yard operations
- An alarm is sounded, and the hoist is stopped, if the system detects the truck cabin is in a dangerous position
- May reduce energy consumption due to reduced gantry movement.

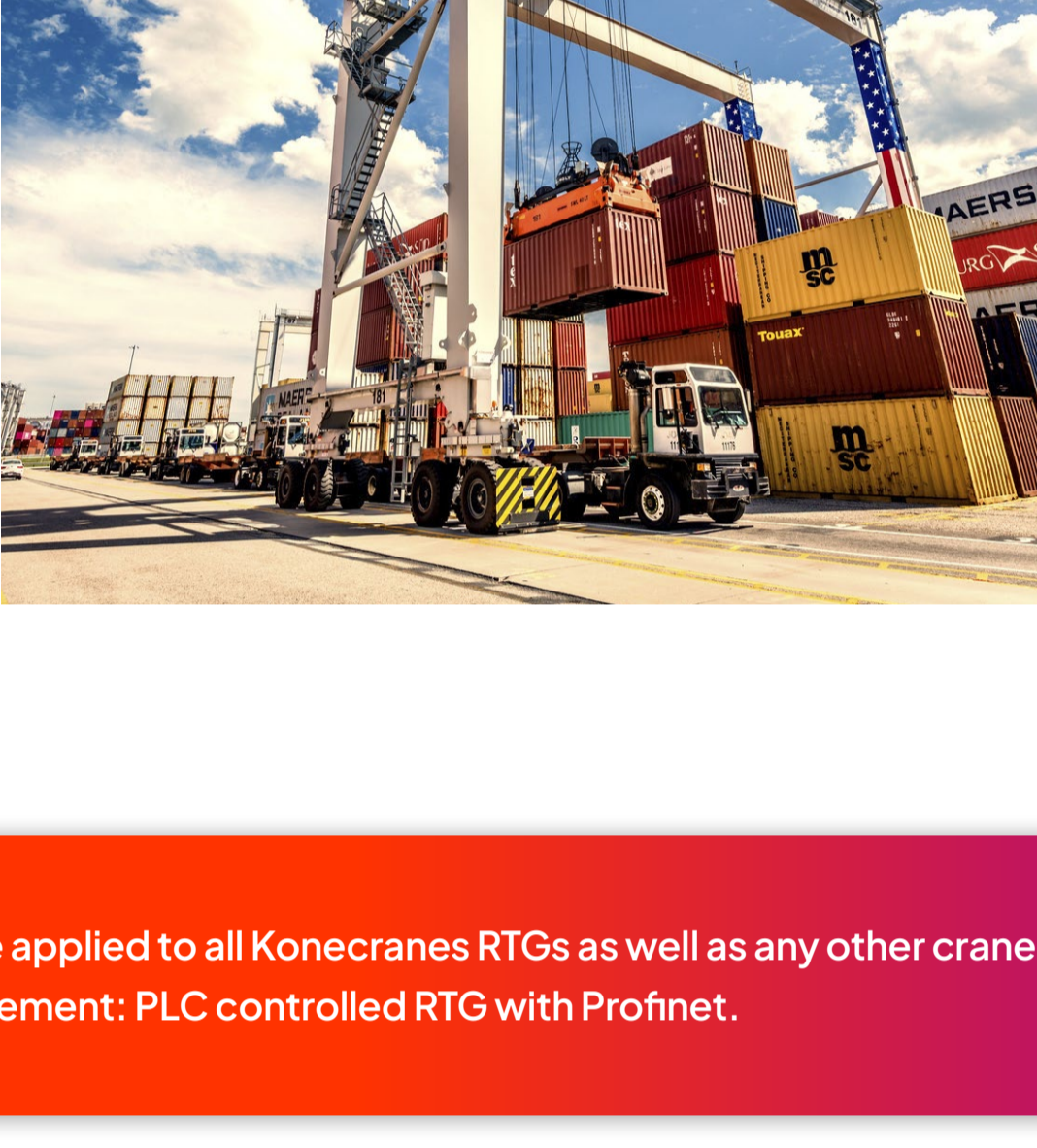

AB
Any Brand

This technology can be applied to all Konecranes RTGs as well as any other crane brand. Minimum requirement: PLC controlled RTG with Profinet.

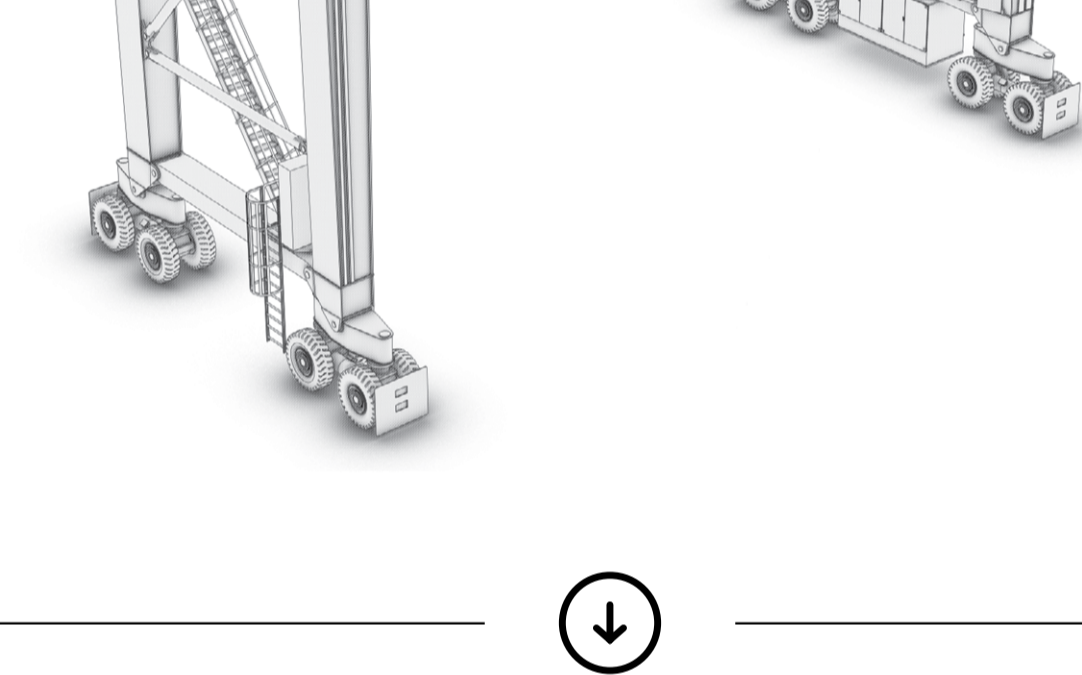

RTG
Rubber-Tired Gantry Crane



How it works

- The system uses a laser scanner mounted between the crane legs on the truck lane side
- Guiding lights (similar to traffic lights) are installed on the crane structure, visible to the truck operator either directly or from the side-view mirror
- The laser scanner then empties the profile of the truck beneath the crane and detects whether it is loaded, partly loaded or empty
- The TOS then provides information about where the truck is to be positioned
- The Auto Truck Guiding system then signals the truck driver to park the truck in the desired position.

What you need to know

- Auto-Steering and Auto-TOS reporting are required when offering Auto-Truck guiding
- Weather must be taken into consideration; cabling and sensors have maximum and minimum temperature requirements
- Site works and commissioning: 2 days per crane
- Product is mandatory for further automation
- Customer needs to provide safe location where installation and commissioning can be completed.



Selected References



YEAR	CUSTOMER/LOCATION	QUANTITY
2019	DPW / Djazair	5
2019	PTP / Johor	12
2018	PMT / Kuala Tanjung	8
2016	DCT / Gdansk	16
2015/20	DPW / Yarimca	6
2016	DPW / Maputo	6

Ports. Evolved.

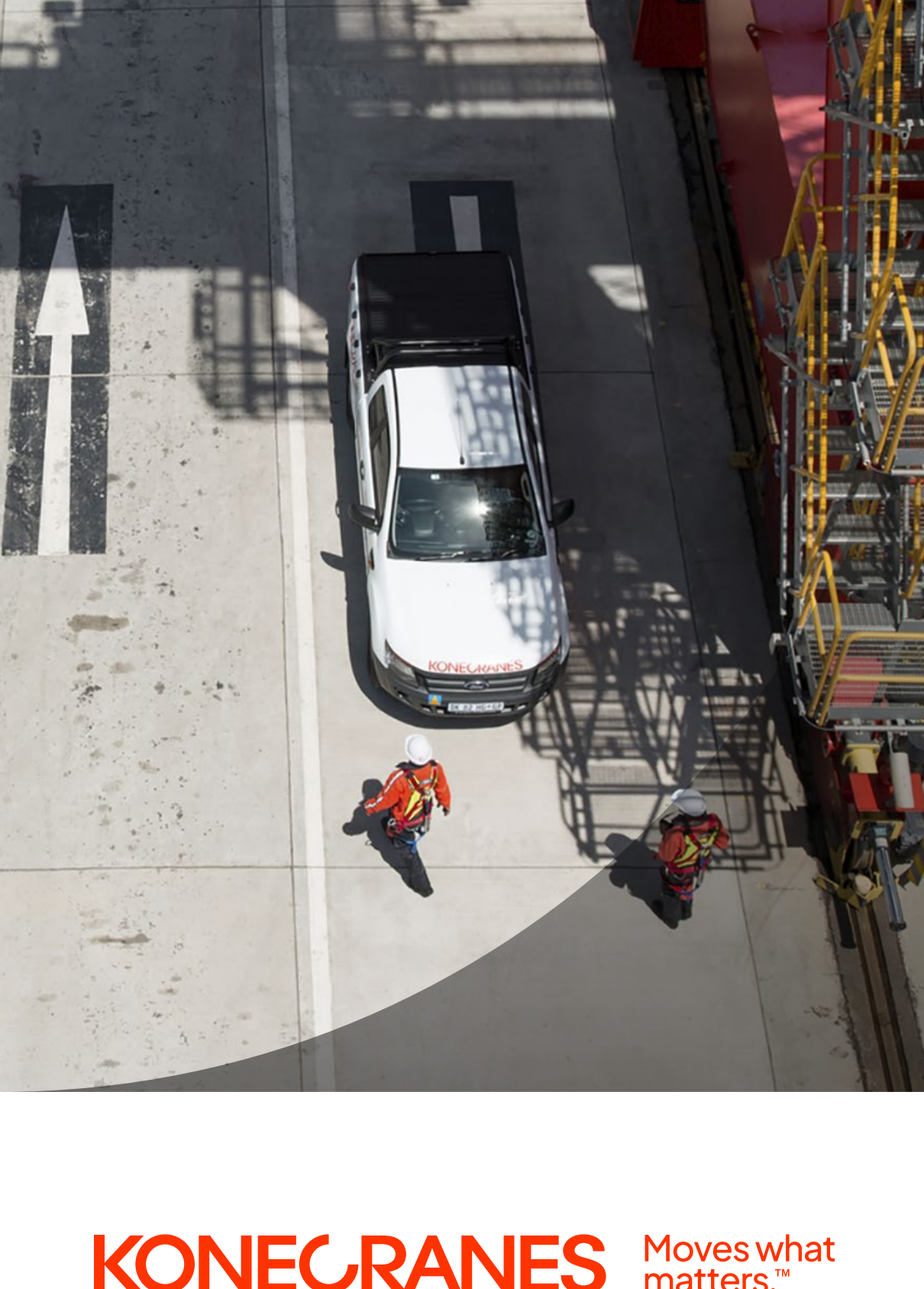

Konecranes is a global leader in material handling solutions, serving a broad range of customers across multiple industries. We consistently set the industry benchmark, from everyday improvements to the breakthroughs at moments that matter most, because we know we can always find a safer, more productive and sustainable way. That's why, with around 16,600 professionals in over 50 countries, Konecranes is trusted every day to lift, handle and move what the world needs. In 2023, Group sales totalled EUR 4.0 billion. Konecranes shares are listed on Nasdaq Helsinki (symbol: KCR).

© 2024 Konecranes. All rights reserved. 'Konecranes', 'Moves what matters' and  are either registered trademarks or trademarks of Konecranes.

This publication is for general informational purposes only. Konecranes reserves the right at any time, without notice, to alter or discontinue the products and/or specifications referenced herein. This publication creates no warranty on the part of Konecranes, express or implied, including but not limited to any implied warranty or merchantability or fitness for a particular purpose.