

[contact us](#)

How do

Octopi pick locks, store tools, solve puzzles and open jars?

Each arm has evolved a semi-autonomous brain for swifter more informed decision-making.

Control. Evolved.



Automation Retrofits

A set of adaptations that enable each crane in your yard to operate automatically and remotely.

Automation Retrofit

The complete suite of smart features, remote operation systems and automated yard infrastructure features.



Watch video at this link

Adapt and thrive

Konecranes is the premier port services provider to brownfield terminal developments. Our range of retrofit products will enable your fleet to adapt to a fast-changing environment. Welcome to your evolution.

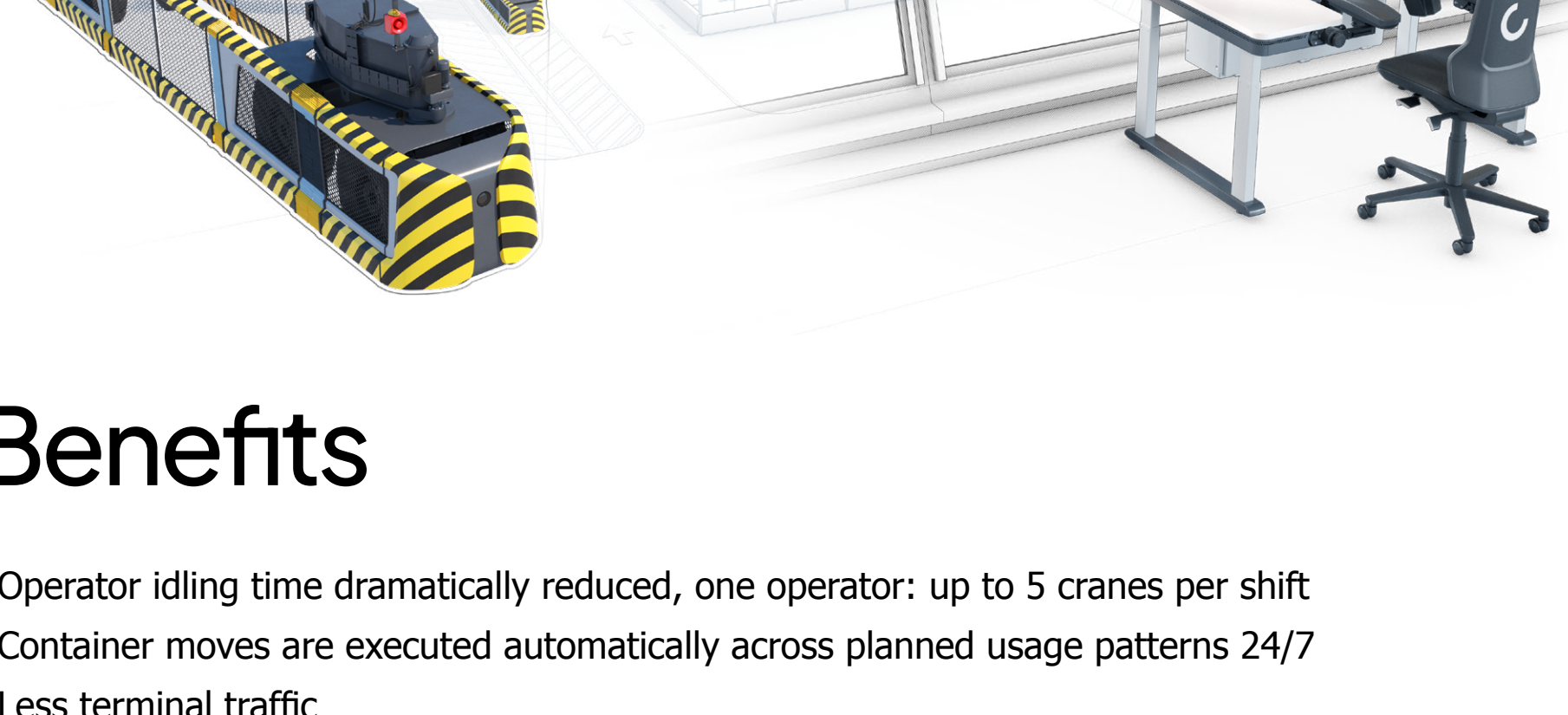

Benefits

- Operator idling time dramatically reduced, one operator: up to 5 cranes per shift
- Container moves are executed automatically across planned usage patterns 24/7
- Less terminal traffic
- Decreased operational cost
- Reduced environmental impact
- Our ARTG system can be introduced in controlled phases, at reasonable cost, with minimal interruptions to terminal operations.

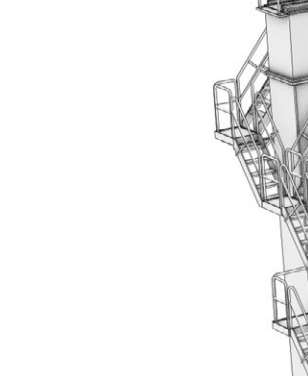
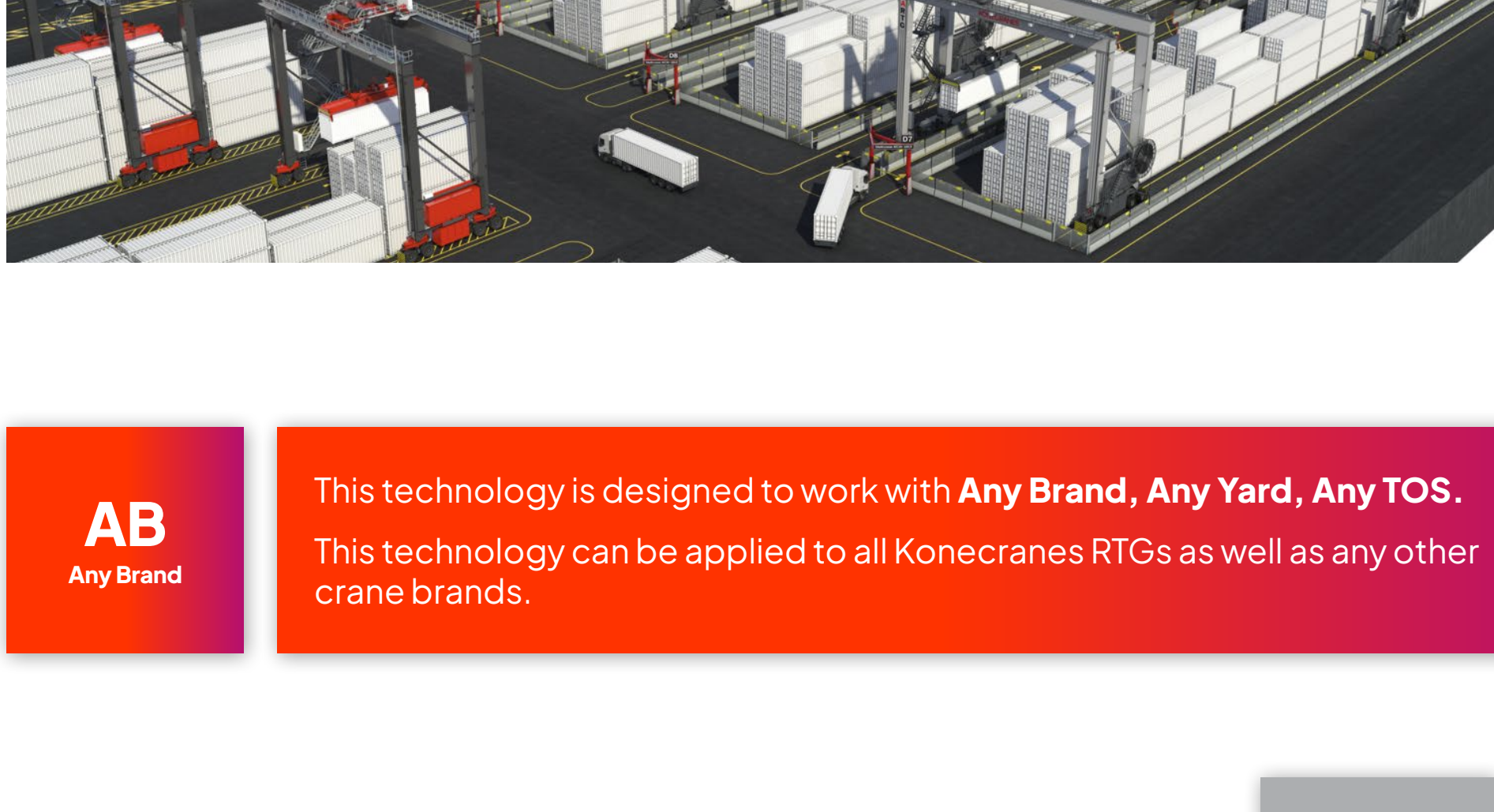

This technology is designed to work with **Any Brand, Any Yard, Any TOS**. This technology can be applied to all Konecranes RTGs as well as any other crane brands.

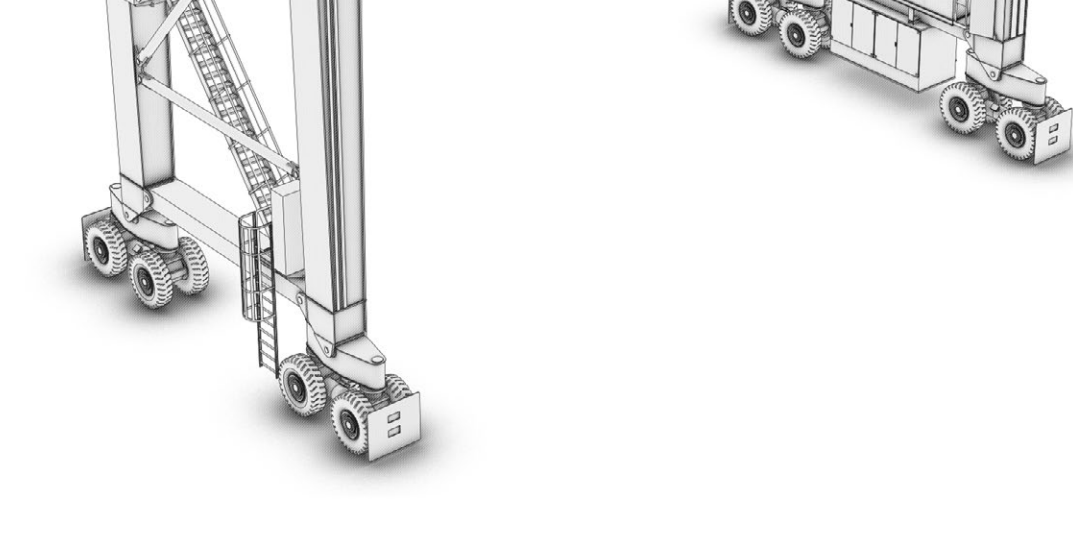

RTG
Rubber-Tired Gantry Crane



Why Konecranes Automation?

- Our automation system comes with a performance guarantee – an industry first
- Konecranes has the most field-proven retrofit/brownfield automation concepts
- Our proprietary Active Load Control technology is a huge advantage in converting manual yards to automated
- Field-proven entirely wireless communications technology for Konecranes video signals, enabling even diesel genset RTGs to be automated
- Deep technical support by way of a remote Crane Management System, as well as augmented reality technology in the field

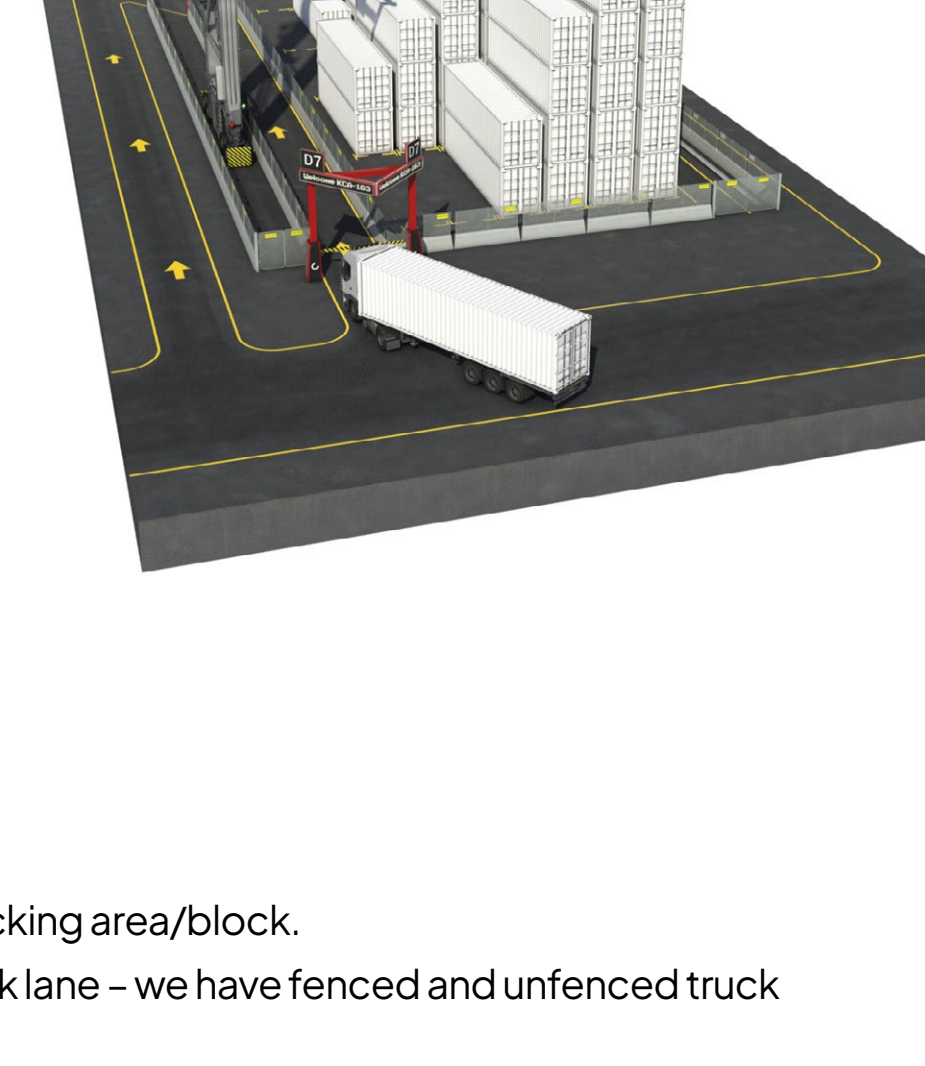
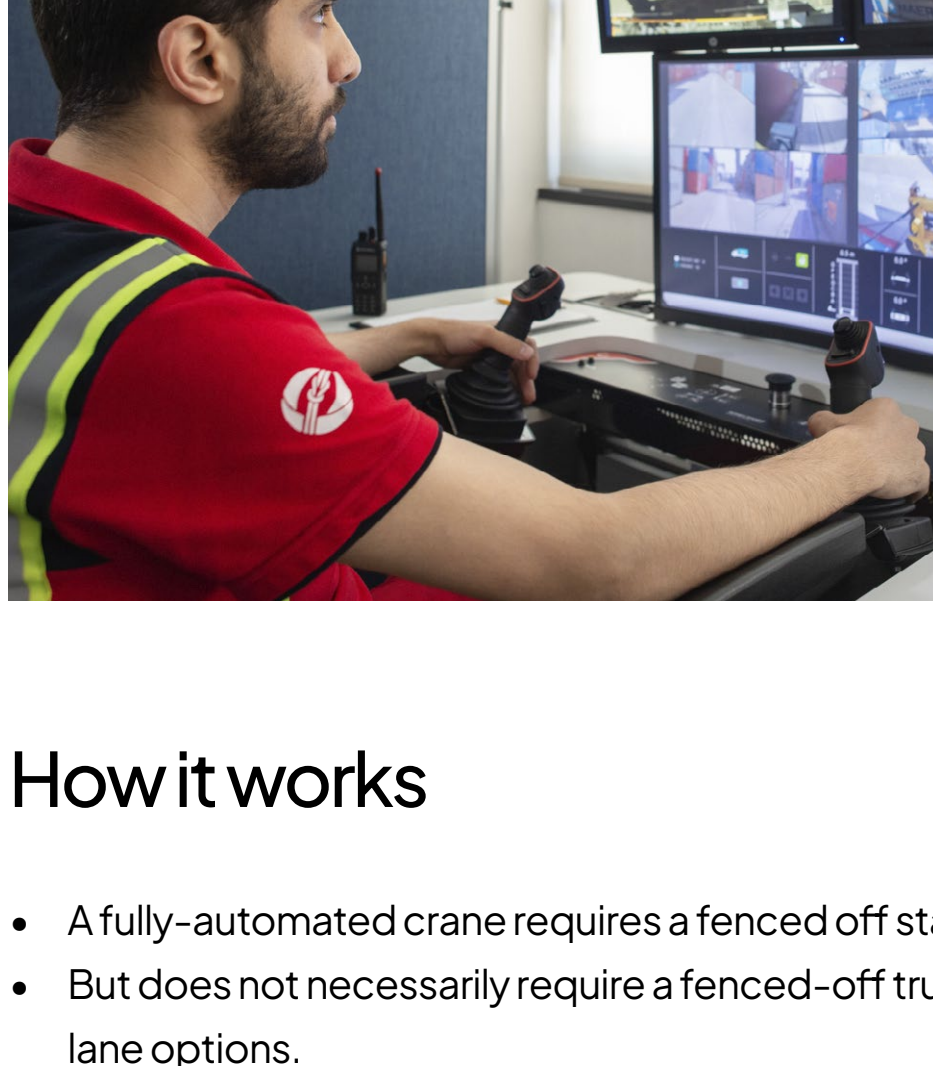

How it works

- A fully-automated crane requires a fenced off stacking area/block.
- But does not necessarily require a fenced-off truck lane – we have fenced and unfenced truck lane options.
- When inside the fenced stacking area/block the crane will automatically move into position, pick up and drop off container based on instructions directly from the TOS.
- 1 to 2 Automated RTGs can operate in a block at a time.
- Operators only handle exceptional moves and truck loading and unloading.
- Truck lanes have entry and exit gates that use RFID tags to identify the correct truck, and use LED screens to issue instructions to the driver.
- Once verified the truck's movement triggers the work instruction from the TOS to the ARTG, which moves the crane and container into position above the truck.
- The crane then pings the operations centre and requests a remote operator to complete the lift or delivery of the container from or to the truck.
- When outside of the fenced area (for maintenance etc.) the crane is handled via remote operation or via the cabin.



Selected References

(Click on for the full case study.)

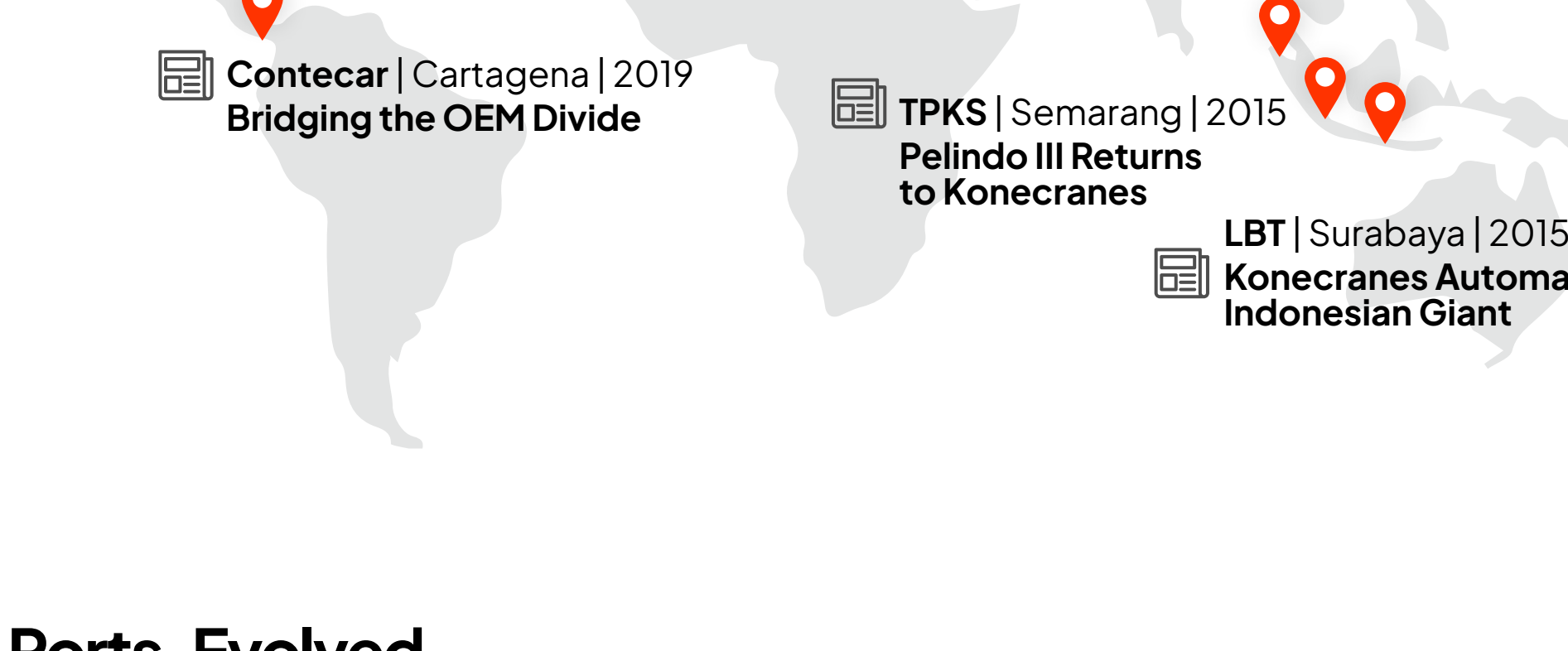

Ports. Evolved.



Konecranes is a global leader in material handling solutions, serving a broad range of customers across multiple industries. We consistently set the industry benchmark, from everyday improvements to the breakthroughs at moments that matter most, because we know we can always find a safer, more productive and sustainable way. That's why, with around 16,600 professionals in over 50 countries, Konecranes is trusted every day to lift, handle and move what the world needs. In 2023, Group sales totalled EUR 4.0 billion. Konecranes shares are listed on Nasdaq Helsinki (symbol: KCR).

© 2024 Konecranes. All rights reserved. "Konecranes", "Moves what matters" and are either registered trademarks or trademarks of Konecranes.
This publication is for general informational purposes only. Konecranes reserves the right at any time, without notice, to alter or discontinue the products and/or specifications referenced herein. This publication creates no warranty on the part of Konecranes, express or implied, including but not limited to any implied warranty of merchantability or fitness for a particular purpose.