

How do

# crickets detect danger?

They have evolved small hairs that can detect the air current of a nearby frog opening its mouth.

Safety. Evolved.



## Safety-Assist Retrofits

Crane adaptations that detect danger and enable safer operations.

### Gantry Collision Prevention

Assists in avoiding crane-to-crane and crane-to-obstacle collisions.



Watch video at this link

## Adapt and thrive

Konecranes is the premier port services provider to brownfield terminal developments. Our range of retrofit products will enable your fleet to adapt to a fast-changing environment. Welcome to your evolution.

## Benefits

- Laser sensors in the system perform slowdown and stop-limits within a 20-meter range
- The system works in every mode of gantry travel: normal, cross and rotate
- Longer range and better weather tolerance compared to ultra-sonic sensors
- Simplest and most accurate solution in the market
- Highly resistant to adverse weather.



**AB**  
Any Brand

This technology can be applied to the following Konecranes equipment and any other crane brand. Installation of laser sensor and PLC connection may vary Any Brand when implementing system to other brands.

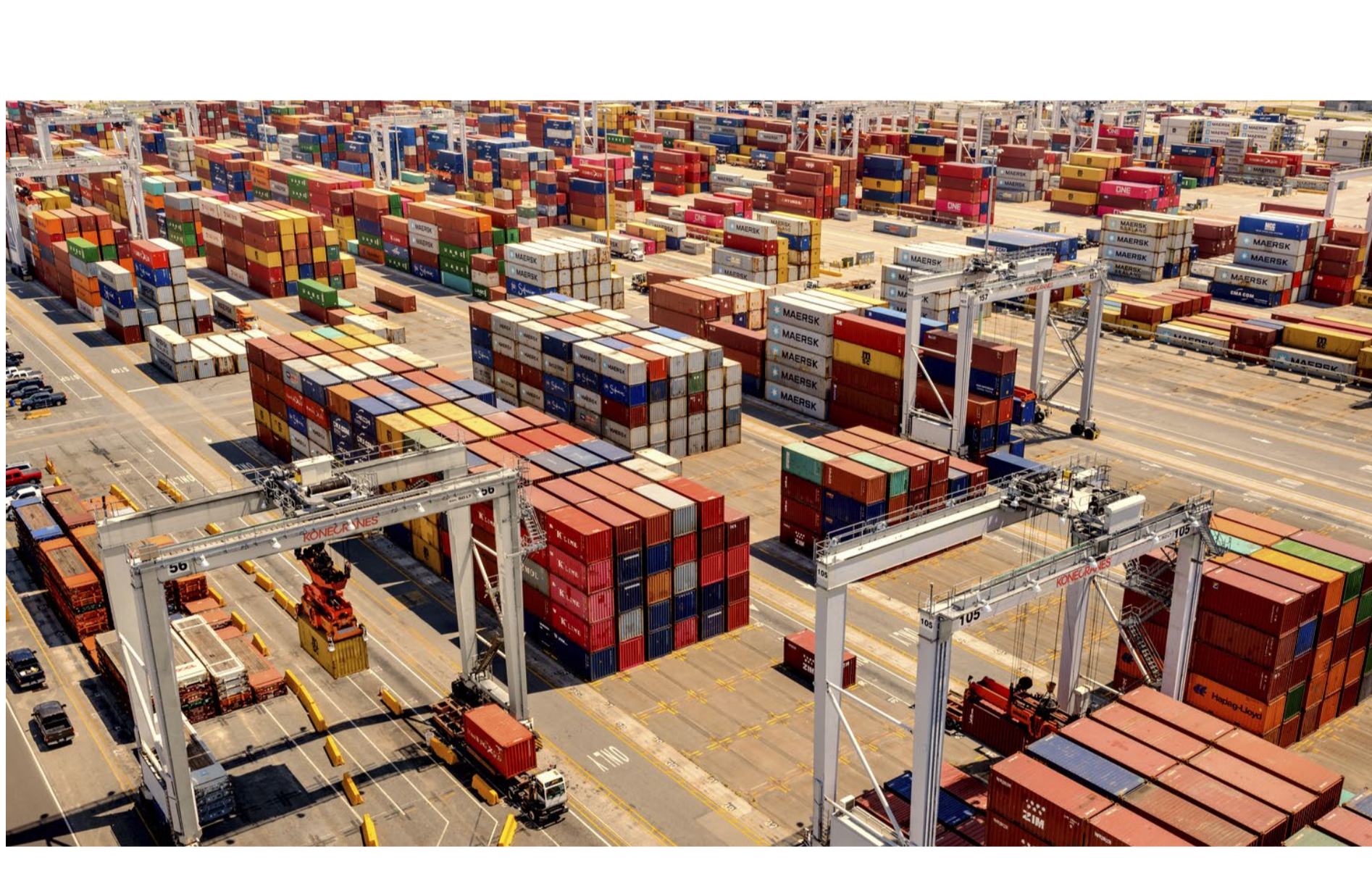
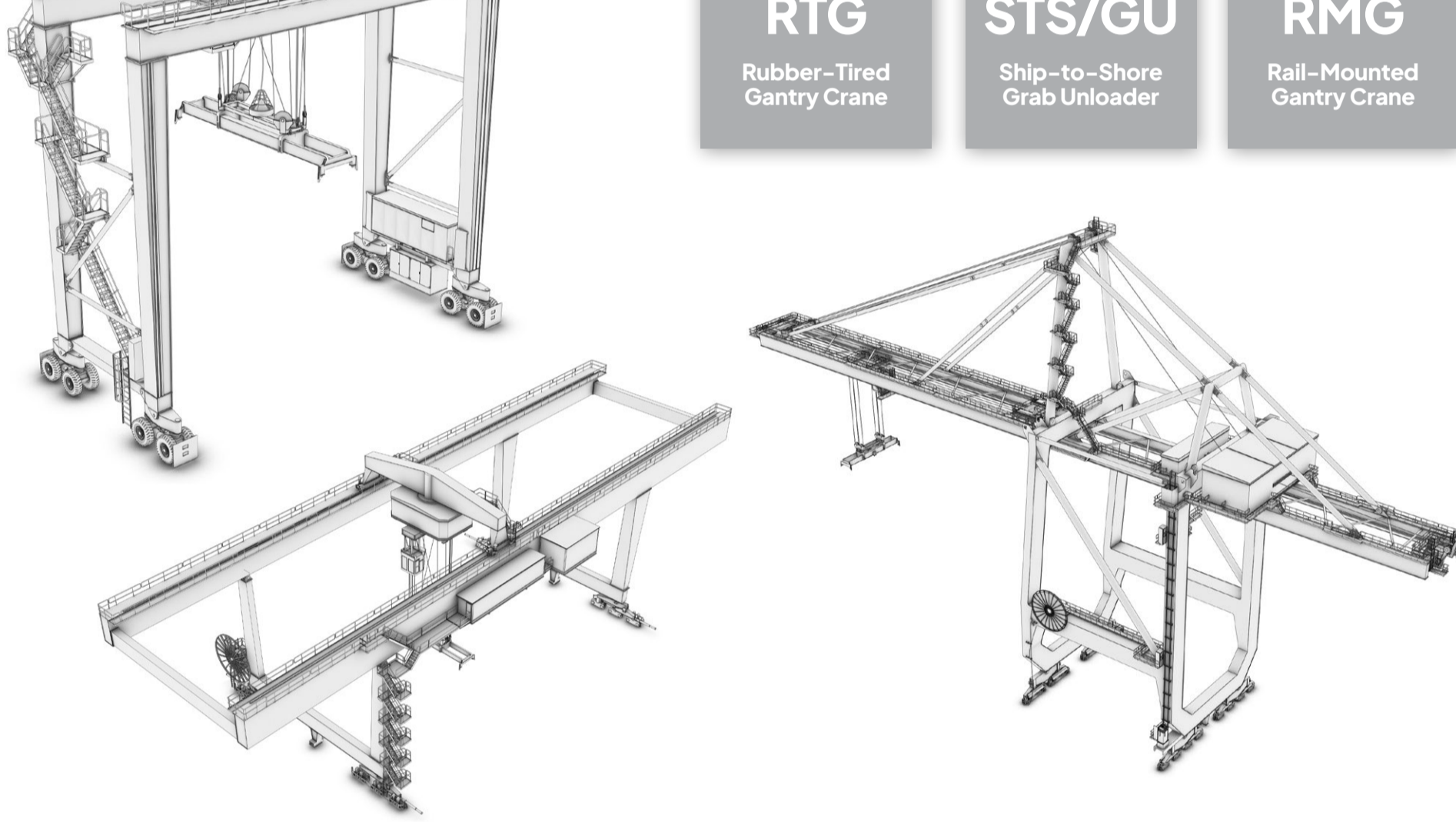

### How it works

- A laser sensor is installed on each RTG bogie
- Safety zones are pre-programmed to comply with local regulations and your own yard requirements
- If a laser sensor detects something inside the safety zone, the crane stops moving
- Operators are informed of the system status at all times.

### What you need to know

- Gantry collision prevention is mandatory with further automation
- Turn-key project delivery with all required hardware and software plus training
- Site works and commissioning: 2 days per crane
- Customer needs to ensure prompt availability of cranes to ensure the above timelines
- Installation needs to provide safe location where installation and commissioning can be completed.



### Selected References



YEAR	CUSTOMER/LOCATION	QUANTITY
2022	PHA / USA	8
2022	Port Everglades / USA	4
2020	Luka Koper / Slovenia	2
2019	TMS / Spain	3
2019	SCPA / USA	18
2018	APMT / USA	32
2016	APC / Israel	24

### Ports. Evolved.



Konecranes is a global leader in material handling solutions, serving a broad range of customers across multiple industries. We consistently set the industry benchmark, from everyday improvements to the breakthroughs at moments that matter most, because we know we can always find a safer, more productive way. That's why, with around 16,600 professionals in over 50 countries, Konecranes is trusted every day to lift, handle and move what the world needs. In 2023, Group sales totalled EUR 4.0 billion. Konecranes shares are listed on Nasdaq Helsinki (symbol: KCR).

© 2024 Konecranes. All rights reserved. "Konecranes", "Moves what matters" and "C" are either registered trademarks or trademarks of Konecranes.  
This publication is for general informational purposes only. Konecranes reserves the right at any time, without notice, to alter or discontinue the products and/or specifications referenced herein. This publication creates no warranty on the part of Konecranes, express or implied, including but not limited to any implied warranty or merchantability or fitness for a particular purpose.