

# LIFT TRUCKS WITH HEART

# JOIN THE STORY

**Dear Customer,**

Konecranes lift trucks are special. They come with a heritage of fine craftsmanship from the world's heartland of heavy-duty lift trucks, Småland, in southern Sweden. They embody the most highly evolved technology and industrial design in the business. And they come with our people – the most talented, motivated and spirited people in the industry.

I hope you enjoy the journey of this book, and I look forward to meeting you in person.

Sincerely,



Lars Fredin  
Vice President and Head of  
Business Unit Lift Trucks, Konecranes

# LIFT TRUCKS WITH HEART

The hardest-working, longest-lived  
lift trucks in the world

## CONTENTS

Business unit of the Konecranes group.....	8
<b>Lift trucks with heart.....</b>	<b>12</b>
World's heartland of lift trucks .....	14
Our trucks come with our people.....	18
<b>Smarter where it matters.....</b>	<b>30</b>
Fork lift trucks .....	32
Empty container lift trucks .....	34
Laden container lift trucks .....	36
Reach stackers .....	38
The world's widest range of heavy-duty lift trucks .....	40
OPTIMA .....	44
Research and development highlights .....	48
Top tips for improving safety .....	50
How to reduce total cost of ownership.....	52
<b>Satisfied customers.....</b>	<b>54</b>
Port of Helsingborg .....	56
NTB North Sea Terminal Bremerhaven.....	60
BLG Logistics Group AG & Co. ....	64
Weserport GmbH.....	68
Paterson Simons & Co. ....	72
Gränges Sweden AB.....	82
<b>Lift trucks for every application .....</b>	<b>88</b>
Container ports and terminals .....	90
Intermodal and barge handling.....	92
Steel and aluminum .....	96
Mining.....	100
General manufacturing.....	102
Pulp & paper, wood .....	104
Automotive .....	108
Wind power.....	110
Oil & gas .....	114
Nuclear .....	116
Concrete, brick and rock.....	118
Waste-to-energy and biomass.....	120
Customized solutions .....	122

### LIFT TRUCKS WITH HEART

© 2016 Konecranes. All rights reserved.

'Konecranes', 'Lifting Businesses' and  are either registered trademarks or trademarks of Konecranes.

This publication is for general informational purposes only. Konecranes reserves the right at any time, without notice, to alter or discontinue the products and/or specifications referenced herein. This publication creates no warranty on the part of Konecranes, express or implied, including but not limited to any implied warranty or merchantability or fitness for a particular purpose.

kcliftrucks.com  
konecranes.com

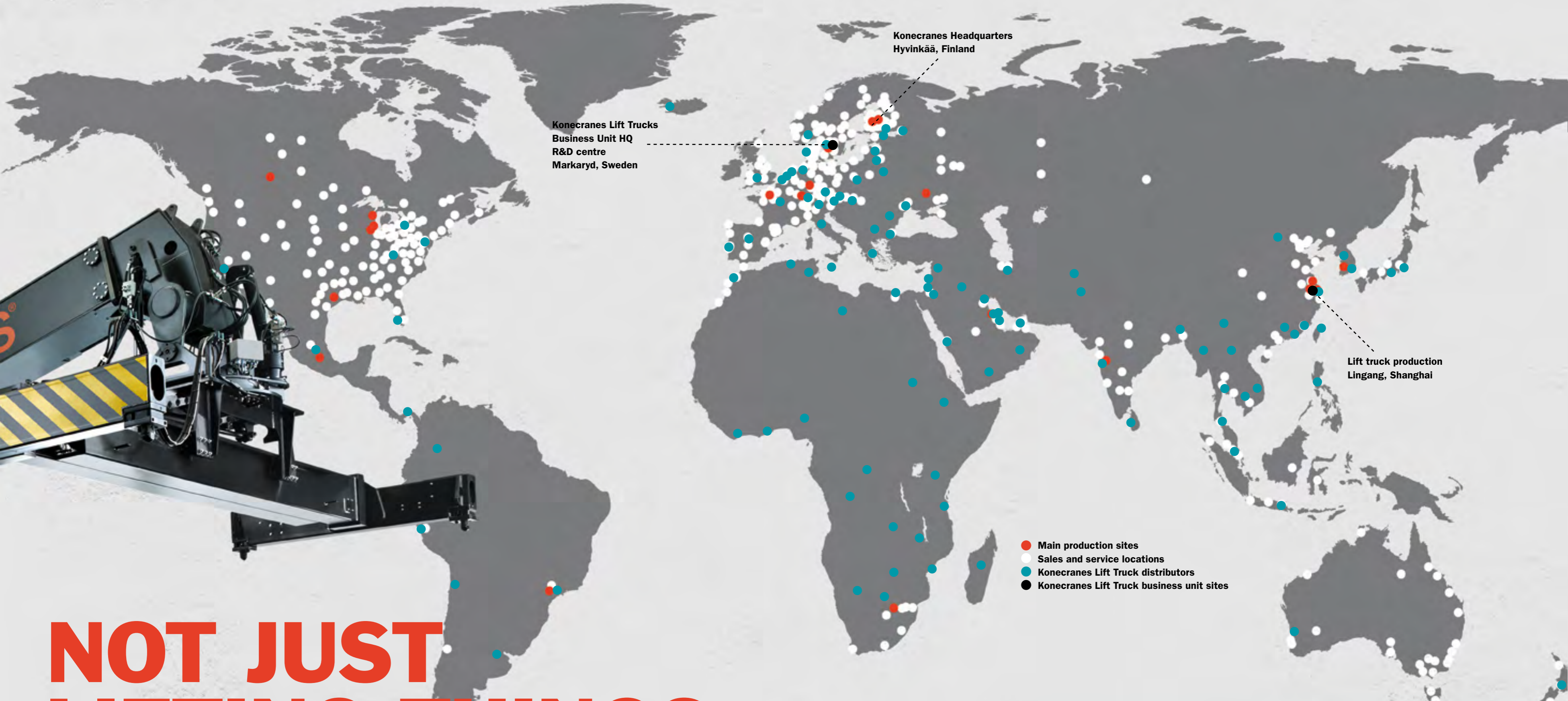

Konecranes Lift Trucks  
Business Unit HQ  
R&D centre  
Markaryd, Sweden

Konecranes Headquarters  
Hyvinkää, Finland

Lift truck production  
Lingang, Shanghai

- Main production sites
- Sales and service locations
- Konecranes Lift Truck distributors
- Konecranes Lift Truck business unit sites

# NOT JUST LIFTING THINGS, BUT ENTIRE BUSINESSES

We are an industry-leading group of lifting businesses with offices and factories around the globe. For over 80 years, we have been dedicated to improving the efficiency and performance of our customers and understanding the specialized processes of each of the industries we serve.

We have done this by continuously providing products and services that people can trust. When you choose Konecranes, you acquire a unique source of global experience and knowledge combined with local know-how to empower your lifting operations and increase your productivity.

Konecranes Lift Trucks,  
a business unit of the

# KONECRANES GROUP

Konecranes is the world's leading provider of lifting equipment and service to a wide range of industries. We supply heavy, customized industrial cranes to process industries, and a range of lighter, standard-duty lifting systems. Jib cranes, chain hoists and workstation lifting systems complete our industrial crane offering.

We are also the world's leading supplier of shipyard cranes to ship-builders worldwide, and a major supplier of container handling cranes to container ports.

On the service side, we are the world's leading supplier of services for lifting equipment, with the ability to service all crane brands and makes on every continent.



**A LARGE,  
SKILLED,  
GLOBAL  
WORKFORCE**

**A FINANCIALLY  
SOUND  
COMPANY**

**PRESENT IN  
ALMOST  
200  
COUNTRIES  
WORLDWIDE**

**1,75  
MILLION ANNUAL  
SERVICE CALLS**

**SERVICE IS  
42%  
OF TOTAL SALES**

**EQUIPMENT IS  
58%  
OF TOTAL SALES**



Konecranes  
**CUSTOMER INDUSTRIES**



**WASTE-TO-ENERGY & BIOMASS**



**PULP & PAPER, WOOD**



**CONCRETE, BRICK & ROCK**



**STEEL, ALUMINUM & MINING**

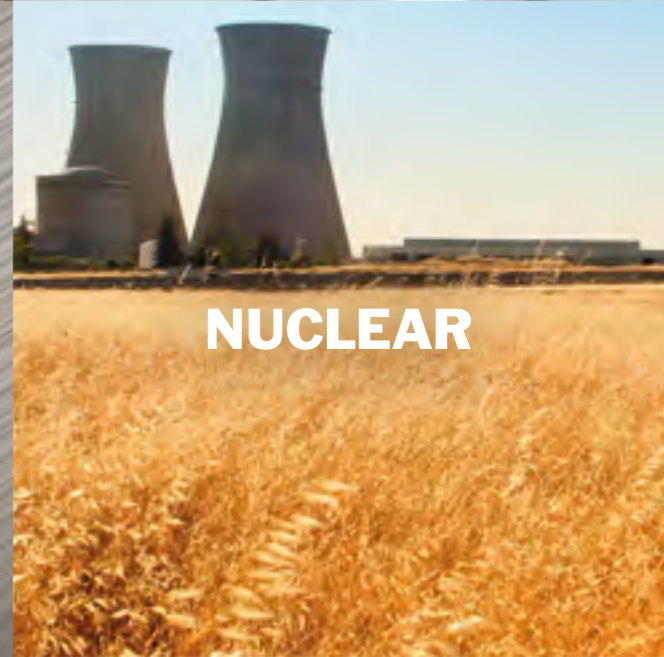

**NUCLEAR**



**CONTAINER PORTS & TERMINALS**



**OIL & GAS**



**GENERAL MANUFACTURING**



**WIND POWER**



**INTERMODAL & BARGE HANDLING**



**AUTOMOTIVE**



# WE MAKE LIFT TRUCKS WITH HEART

We delivered our first lift truck, a fork lift, to a customer in 1959. We put our heart into that first delivery, assembling the truck with great care, looking after the delivery and working life of our first-born to make sure our customer was more than pleased.

Our attitude is exactly the same today. We now sell and support our lift trucks all over the world as part of Konecranes, the world's leading provider of smart lifting solutions. Visit our production facilities and you'll find a close-knit community of Konecranes people with a common passion: making the hardest-working, longest-lived lift trucks in the world.

We live and breathe lift trucks.

Stefan (left) and Lars-Göran (right) have been making Konecranes lift trucks as a team for over ten years. They're tough, skilled truck craftsmen, hard-working and good-humored. You can meet them in our Markaryd factory when you come to inspect the build quality of your trucks.

# WELCOME TO THE WORLD'S HEARTLAND OF LIFT TRUCKS

The province of Småland, in southern Sweden, is the world's heartland of heavy-duty lift trucks. Småland has a greater concentration of heavy-duty lift truck companies, history, heritage, craftsmanship and passion than any other part of the world.

Småland became the world's heartland of heavy-duty lift trucks thanks to its wood industry and the pragmatic nature of its hard-working people. Småland is agriculturally poor but rich in trees: 50% of its surface area is covered by forest. Wood has been a very important part of the province's economy for hundreds of years.



Lift trucks are more than just economically important to Småland. They are something to be passed on with pride to the next generation.



# LEADING THE WAY

As motorized tractors were taken into use by Smålanders in the 1890s and 1900s, some were adapted for wood harvesting by adding home-made masts and forks. By the 1930s, local entrepreneurs were making and selling lift trucks for logging and stacking, showing considerable ingenuity.

Those rough-and-ready early lift trucks were trailblazers, driving the productivity and profitability of their owners' businesses. By the 1970s, Småland boasted a number of important lift truck companies doing business across Scandinavia, Europe and the world.

The history of Konecranes Lift Trucks dates back to the 1950s and the beginning of the modern era of lift truck business. Our heritage lies in southern Sweden and Småland, while our business reach extends across the world. We are continuing the tradition of fine truck craftsmanship, while bringing to it the latest technologies and industrial design.

Konecranes is leading the way from the world's heartland of lift trucks.



Konecranes is committed to its operations in Markaryd, Småland. This is the R&D, industrial design and manufacturing base of the Konecranes Lift Trucks business unit. The office facilities were expanded considerably in 2012 to accommodate growth in the business. Our manufacturing facility in Lingang (Shanghai), China, also produces high-quality trucks, primarily for the Asian market.



# OUR TRUCKS COME WITH OUR PEOPLE

The people who design, build and support Konecranes lift trucks do their work with a special spirit. It comes in part from our long heritage in the lift truck business. We have devoted our working lives to lift trucks – they're in our blood. Many of our fathers have worked in the lift truck business and, in a few cases, even our grandfathers.

The special spirit also comes from our daily contact with customers. We know that we are only as good as our last lift truck and how that truck will perform throughout its working life.

We love the operating challenges that our customers throw at us: the scorching temperatures and blowing sand of deserts; the hard-banging, ceaseless work at container terminals; the special needs for handling attachments that make our engineers scratch their heads, smile, and go straight to the nearest drawing board.



## DEDICATED WORLDWIDE

Konecranes lift trucks are available in over 80 countries through our appointed distributors and Konecranes country operations. In both cases, they are fully supported with spare parts and personalized service and maintenance. Konecranes has the widest service reach of any company in the lifting business. And our distributors are some of the most respected in the lift truck business.



# THE HEART OF OUR TECHNOLOGY

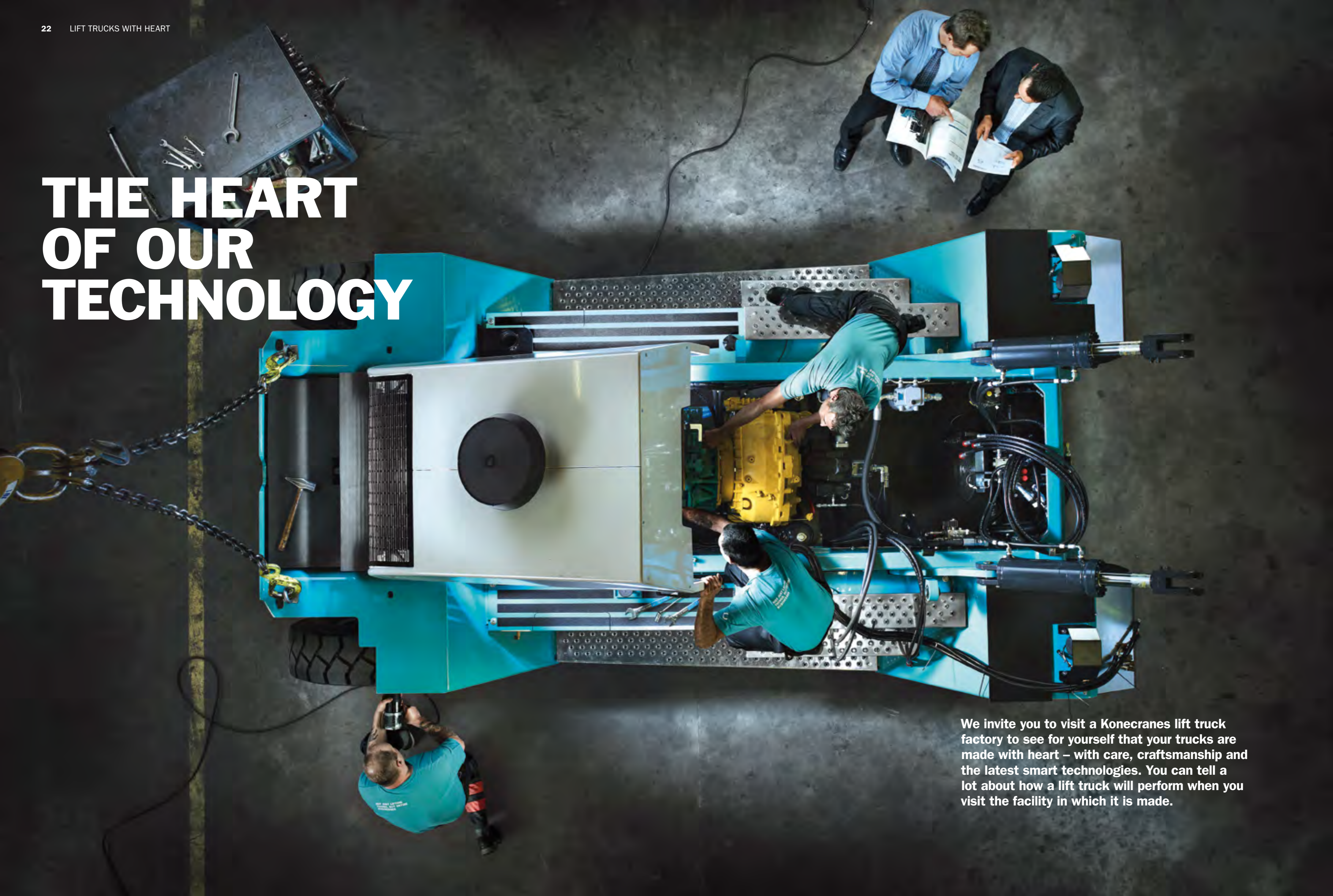

We invite you to visit a Konecranes lift truck factory to see for yourself that your trucks are made with heart – with care, craftsmanship and the latest smart technologies. You can tell a lot about how a lift truck will perform when you visit the facility in which it is made.

# IN THE REAL WORLD

We are keenly interested in how our customers use our trucks in the field. Many of the innovations and refinements we offer are the direct result of customer field experience.



# MADE TO MEASURE

Our R&D engineers are constantly expanding our list of standard features, special options and attachments. Our craftsmen enjoy building your truck according to your individual requirements.





# SMARTER WHERE IT MATTERS

Konecranes lift trucks are made with care, craftsmanship, and the latest smart technologies. The strength, performance and reliability of every Konecranes lift truck is based on three things that make up the heart of our technology: a strong box-type chassis, efficient load-sensing hydraulics and intelligent electronic machine control. And we are always pushing ahead with new services and technology.

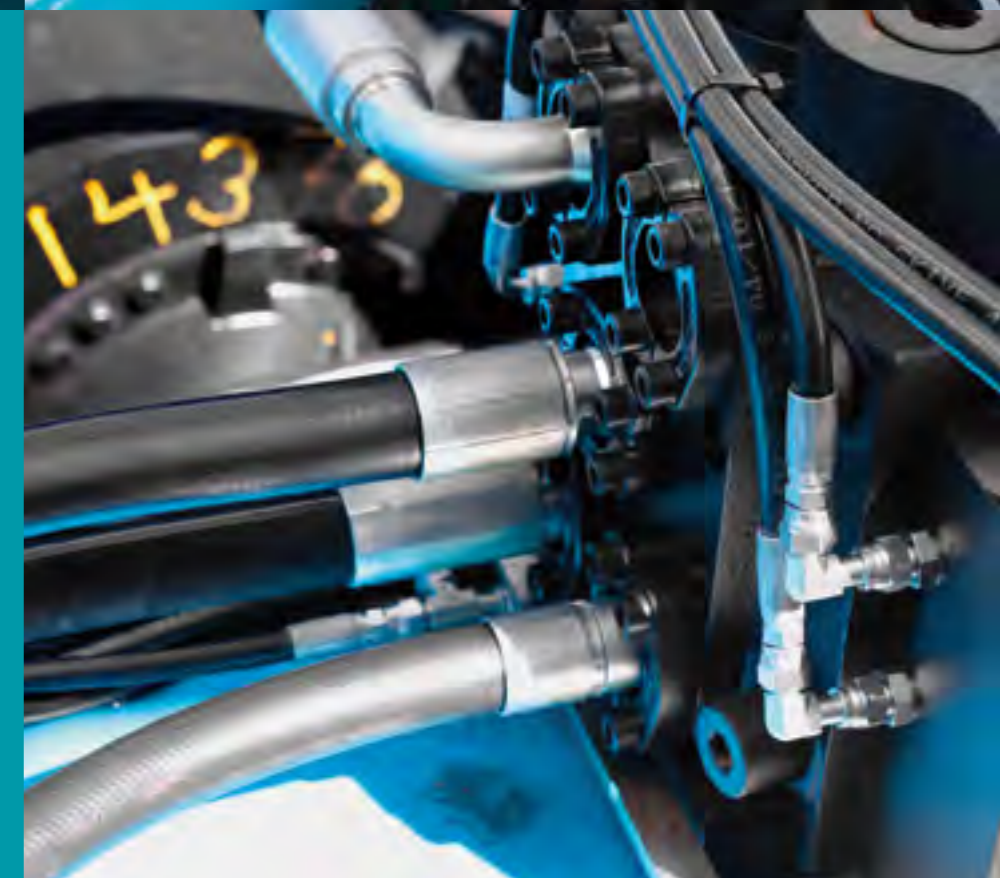



**SMARTER  
WHERE IT  
MATTERS**



# FORK LIFT TRUCKS WITH HEART

## 1 Powerful engines

Certified low-emission engines provide extra high torque at low revs, reduced fuel consumption, and low noise levels. We offer a variety of engines for EU stage 4 and EPA Tier 4f.

## 2 OPTIMA – probably the best cabin on the market

Every detail has been carefully designed for comfort and safety. Controls, displays, ventilation, and seating work to boost driver productivity. Excellent visibility in all directions.

## 3 Empower the truck for your operation

Select the right lifting mast from our wide range. Choose between Duplex (with or without free lift) and Triplex (with free lift).

## 4 Smart load-sensing hydraulics

They sense the load and adapt the lifting power to the weight of the load. The truck provides maximum power only when really needed, so it consumes less fuel while reducing emissions and noise.

## 5 Quick-change fork system

Different forks, coil rams, other attachments. What do you need to handle? Steel, wood, paper, containers? Something extraordinary? We'll provide the right attachment for the work you need to do.

## 6 Maintenance-free brakes

Brakes with continuous oil cooling provide full braking power in every situation.

## 7 Heavy-duty box-type chassis

The strongest on the market. The foundation of long-lasting high performance.

## 8 Electronic Machine Control, EMC Master

Full monitoring of all the vital components and functions on a 7" touch screen. Programmable settings. CanBus technology increases engine and transmission reliability as well as hydraulics and levers.

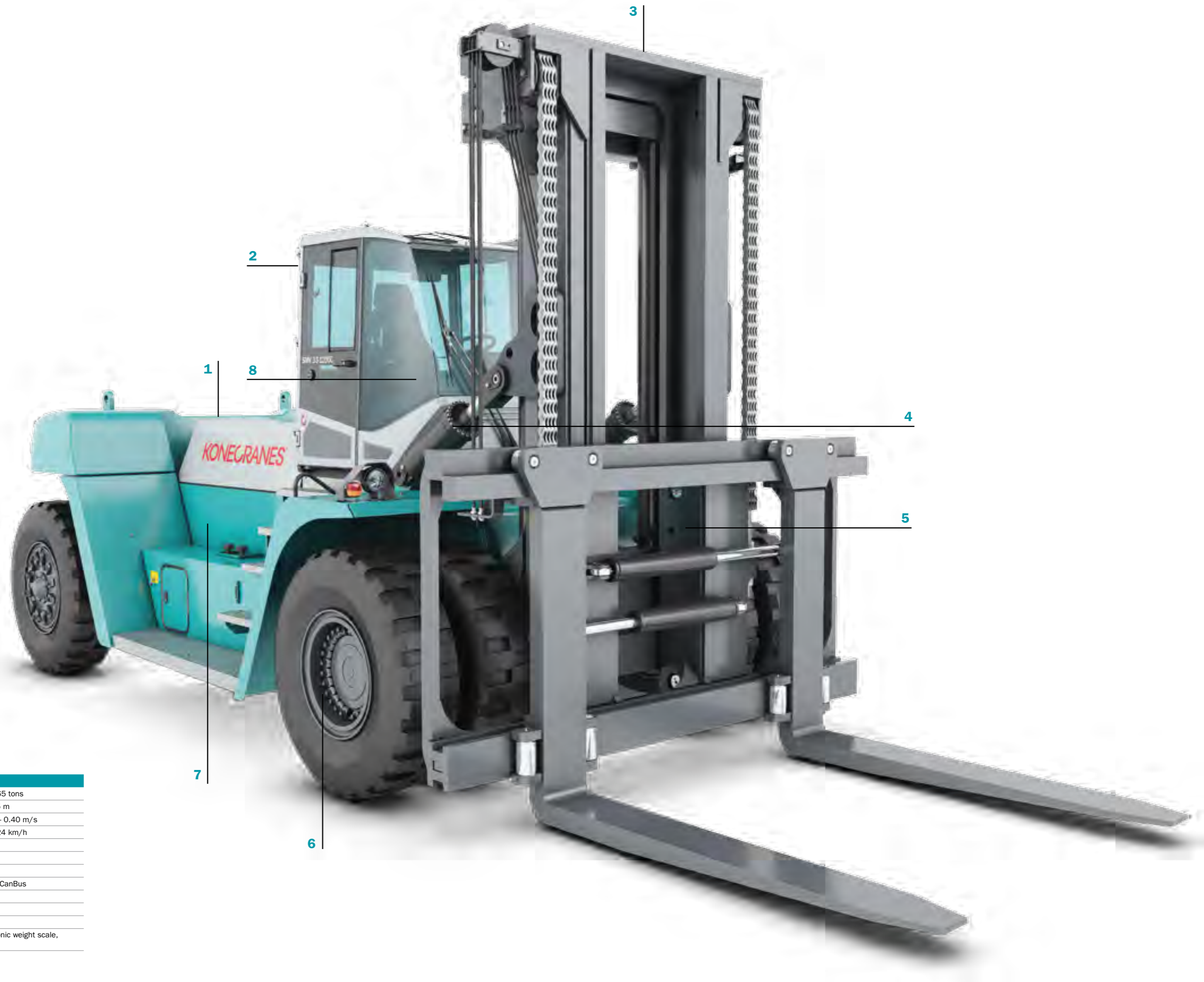

## FORK LIFT TRUCKS 10 – 65 TONS

Technical data	Small	Medium	Large
Lifting capacity	10 – 18 tons	18 – 33 tons	37 – 65 tons
Lifting height	3 – 12 m	3 – 15 m	4 – 15 m
Lifting speeds	0.30 – 0.60 m/s	0.25 – 0.40 m/s	0.15 – 0.40 m/s
Drive speeds	30 – 30 km/h	27 – 29 km/h	22 – 24 km/h
Hydraulics	Load-sensing, low-energy, low fuel consumption		
Lifting equipment	Forks, container spreaders, coil rams, paper clamps etc.		
Engine approvals	EU stage 2, 3a, 4 and EPA Tier 2, 3 and 4f		
Engine types	4-cylinder and 6-cylinder, turbo-charged, intercooler, electronic controls, CanBus		
Transmission	Fully automatic, electronic-hydraulic shift, reverse protection, CanBus		
Brake system	Maintenance-free wet-disc brakes on drive tires, continuous oil cooling		
Hydraulics	Load-sensing, power-on-demand, low-energy, low fuel consumption		
Optional features	Error code data log, ECO-driving, multi-driver login, mini-steering, electronic weight scale, TRUCONNECT® Remote Monitoring and Reporting for lift trucks		

# EMPTY CONTAINER LIFT TRUCKS WITH HEART

**1 Very fast lifting and lowering**

The trucks can lift 8 containers high thanks to the wide mast: hoses and cables are kept to a minimum for low maintenance costs and maximum uptime. Heavy-duty mast and tilt cylinder solution for high stability and safety.

**2 Electronic Machine Control, EMC Master**

Full monitoring of all the vital components and functions on a 7" touch screen. Programmable settings. CanBus technology increases engine and transmission reliability as well as hydraulics and joystick.

**3 OPTIMA – probably the best cabin on the market**

Every detail has been carefully designed for comfort and safety. Controls, displays, ventilation, and seating work to boost driver productivity. Excellent visibility in all directions.

**4 Powerful engine**

Certified low-emission engine provides extra high torque at low revs, reduced fuel consumption, and low noise levels. We offer a variety of engines for EU stage 4 and EPA Tier 4f.

**5 Smart load-sensing hydraulics**

They sense the load and adapt the lifting power to the weight of the load. The truck provides maximum power only when really needed, so it consumes less fuel while reducing emissions and noise.

**6 Single and double stacking**

Sidelift handling of 20–40 ft containers, 45–53 ft containers are lifted in 40 ft position with the twistlocks only. Large sideshift, mechanical pile slope, and optional hydraulic pile slope. Single mode lifts up to 8 containers high. Double mode lifts up to 2-over-6.

**7 Maintenance-free brakes**

Brakes with continuous oil cooling provide full braking power in every situation.



**EMPTY CONTAINER LIFT TRUCKS 8 – 10 TONS**

Technical data	Small	Medium	Large
Lifting capacity	8 tons	9 tons	10 tons
Stacking height	3 – 6 containers	4 – 8 containers	4 – 8 containers
Lifting speeds	0.45 – 0.52 m/s	0.61 – 0.68 m/s	0.61 – 0.68 m/s
Drive speeds	25 – 25 km/h	25 – 25 km/h	25 – 25 km/h
Hydraulics	Load-sensing, low-energy, low fuel consumption		
Spreaders	Sidelift 20 – 40 ft (45 – 53 ft in 40 ft castings), single or double lift		
Functions	Sideshift ± 300/± 600 mm, mechanical pile slope 0 – 200 mm or hydraulic pile slope ± 6 degrees		
Engine approvals	EU stage 2, 3a, 4 and EPA Tier 2, 3 and 4f		
Engine types	4-cylinder and 6-cylinder, turbo-charged, intercooler, electronic controls, CanBus		
Transmission	Fully automatic, electronic-hydraulic shift, reverse protection, CanBus		
Brake system	Maintenance-free wet-disc brakes on drive tires, continuous oil cooling		
Hydraulics	Load-sensing, power-on-demand, low-energy, low fuel consumption		
Optional features	Error code data log, ECO-driving, multi-driver login, mini-steering, electronic weight scale, TRUCONNECT® Remote Monitoring and Reporting for lift trucks		

# LADEN CONTAINER LIFT TRUCKS WITH HEART

**1 Reliable lifting**

Lift masts adapted for laden container handling. Hoses and cables kept to a minimum for low maintenance costs and maximum uptime.

**2 Single stacking spreader**

Toplift handling of 20–40 ft containers, 45–53 ft containers are lifted in 40 ft position with the 4 twistlocks. There are 4 lift eyes for sling cargo, large sideshift, reach in & out, slew left & right, and mechanical pile slope. Large sideshift, mechanical pile slope, and optional hydraulic pile slope.

**3 Maintenance-free brakes**

Brakes with continuous oil cooling provide full braking power in every situation.

**4 Powerful engine**

Certified low-emission engine provides extra high torque at low revs, reduced fuel consumption, and low noise levels. We offer a variety of engines for EU stage 4 and EPA Tier 4f.

**5 Excellent stability**

Wide drive axle and long wheelbase: the two keys to excellent stability.

**6 Heavy-duty box-type chassis**

The strongest on the market. The foundation of long-lasting high performance.

**7 OPTIMA – probably the best cabin on the market**

Every detail has been carefully designed for comfort and safety. Controls, displays, ventilation, and seating work to boost driver productivity. Excellent visibility in all directions.

**LADEN CONTAINER LIFT TRUCKS 33 – 45 TONS**

Technical data	Medium	Large
Lifting capacity	33 – 35 tons	38 – 45 tons
Stacking height	3 – 5 containers	3 – 5 containers
Lifting speeds	0.21 – 0.35 m/s	0.21 – 0.35 m/s
Drive speeds	22 – 24 km/h	22 – 26 km/h
Hydraulics	Load-sensing, low-energy, low fuel consumption	
Spreaders	Toplift 20 – 40 ft (45 – 53 ft in 40 ft castings), single lift only	
Functions	Sideshift ± 200 mm, mechanical or hydraulic pile slope ± 4.8 degrees, slew ± 6.0 degrees, reach 0 – 240 mm	
Engine approvals	EU stage 2, 3a, 4 and EPA Tier 2, 3 and 4f	
Engine types	6-cylinder, turbo-charged, intercooler, electronic controls, CanBus	
Transmission	Fully automatic, electronic-hydraulic shift, reverse protection, CanBus	
Brake system	Maintenance-free wet-disc brakes on drive tires, continuous oil cooling	
Hydraulics	Load-sensing, power-on-demand, low-energy, low fuel consumption	
Optional features	Error code data log, ECO-driving, multi-driver login, mini-steering, electronic weight scale, TRUCONNECT® Remote Monitoring and Reporting for lift trucks	



# REACH STACKERS WITH HEART

**1 Modern and durable lifting spreaders**

Top-lift for 20/40/53 ft containers, 300 degrees rotation, 1600 mm total sideshift, 4 lift eyes for sling cargo. MPS mechanical (±2 deg) or HPS hydraulic pile slope (±6 deg). The combi spreader can also lift trailers and swap bodies with 4 folding lift legs.

**2 Smart load-sensing hydraulics**

They sense the load and adapt the lifting power to the weight of the load. The truck provides maximum power only when really needed, so it consumes less fuel while reducing emissions and noise.

**3 Powerful engine**

Certified low-emission engine provides extra high torque at low revs for reduced fuel consumption and low noise levels. We offer a variety of engines for EU stage 4 and EPA Tier 4f.

**4 OPTIMA – probably the best cabin on the market**

Every detail has been carefully designed for comfort and safety. Controls, displays, ventilation, and seating work to boost driver productivity. Excellent visibility in all directions.

**5 Electronic Machine Control, EMC Master**

Full monitoring of all the vital components and functions on a 7" touch screen. Programmable settings. CanBus technology increases engine and transmission reliability as well as hydraulics and joystick control.

**6 Heavy-duty box-type chassis**

The strongest on the market. The foundation of long-lasting high performance.

**7 Maintenance-free brakes**

Brakes with continuous oil cooling provide full braking power in every situation.

**8 Excellent stability**

Wide, strong drive axle and long wheelbase. The two keys to excellent stability for safe lifting of heavy loads.



**REACH STACKERS 10 – 80 TONS**

Technical data	Empty container stackers	Laden container stackers	Railroad/barge stackers	Industrial stackers
Lifting & handling	Empty containers	Laden containers	Containers, trailers & bulk	Industrial cargo
Stack density (TEU/hectare)	400 – 1600	250 – 750	250 – 750	
Main features	Versatile & fast	Versatile & fast	Versatile & fast	Versatile & fast
Investment/running cost	Low/low	Low/low	Low/low	Low/low
Lifting capacity min (1-2-3 row)	10 – 8 – 5 tons	41 – 27 – 14 tons	41 – 23 – 9 tons	10 – 30 tons
Lifting capacity max. (1-2-3 row)	25 – 18 – 8 tons	45 – 45 – 45 tons	45 – 45 – 45 tons	30 – 80 tons
Container stacking	3 – 6 containers	5 – 6 containers	4 – 5 containers	8 – 16 m
Stacking height	10 – 16.4 m	15.3 – 16.4 m	12 – 15 m	8 – 16 m
Drive speeds	22 – 30 km/h	22 – 26 km/h	22 – 26 km/h	22 – 26 km/h
Spreaders	Toplift 20 – 40 ft (45 – 53 ft in 40 ft castings), trailer lift (combi), over-height spreader, specials or industrial (steel grab, magnet, C-hook, lift hook-beam, vacuum etc.)			
Spreader functions	Sideshift ± 800 mm, mechanical pile slope ±2 degrees or hydraulic pile slope ± 6 degrees, rotation 300 degrees, telescopic 20 – 40 ft, lifting eyes/slings 4 x 11.25 tons (45 tons)			
Control system	Electronic overload, safety & monitoring system (EMC Master)			
Engine approvals	EU stage 2, 3a, 4 and EPA Tier 2, 3 and 4f			
Engine types	6-cylinder, turbo-charged, intercooler, electronic controls, CanBus			
Transmission	Fully automatic, electronic-hydraulic shift, reverse protection, CanBus			
Brake system	Maintenance-free wet-disc brakes on drive tires, continuous oil cooling			
Hydraulics	Load-sensing, power-on-demand, low-energy, low fuel consumption			
Optional features	Error code data log, ECO-driving, multi-driver login, mini-steering, electronic weight scale, TRUCONNECT® Remote Monitoring and Reporting for lift trucks			

# The world's widest range of HEAVY-DUTY LIFT TRUCKS

## Fork lift trucks, 10 to 18 tons



MODEL NAME	CAPACITY	WHEELBASE
SMV 10-600 C	10 tons at 600 mm	3000 mm
SMV 12-600 C	12 tons at 600 mm	3000 mm

## Fork lift trucks, 18 to 33 tons



MODEL NAME	CAPACITY	WHEELBASE
SMV 18-1200 C	18 tons at 1200 mm	4000 mm
SMV 20-1200 C	20 tons at 1200 mm	4000 mm

## Fork lift trucks, 37 to 65 tons



MODEL NAME	CAPACITY	WHEELBASE
SMV 37-1200 C	37 tons at 1200 mm	5000 mm



MODEL NAME	CAPACITY	WHEELBASE
SMV 10-1200 C	10 tons at 1200 mm	3250 mm
SMV 13.6-600 C	13.6 tons at 600 mm	3250 mm



MODEL NAME	CAPACITY	WHEELBASE
SMV 28-1200 C	28 tons at 1200 mm	4500 mm
SMV 32-1200 C	32 tons at 1200 mm	4750 mm
SMV 33-1200 C	33 tons at 1200 mm	4750 mm



MODEL NAME	CAPACITY	WHEELBASE
SMV 42-1200 C	42 tons at 1200 mm	5500 mm
SMV 45-1200 C	45 tons at 1200 mm	5500 mm
SMV 50-1200 C	50 tons at 1200 mm	6000 mm



MODEL NAME	CAPACITY	WHEELBASE
SMV 12-1200 C	12 tons at 1200 mm	3500 mm
SMV 16-600 C	16 tons at 600 mm	3500 mm
SMV 16-900 C	16 tons at 900 mm	3500 mm



MODEL NAME	CAPACITY	WHEELBASE
SMV 22-1200 C	22 tons at 1200 mm	4250 mm
SMV 23.6-1200 C	23.6 tons at 1200 mm	4250 mm
SMV 25-1200 C	25 tons at 1200 mm	4250 mm



MODEL NAME	CAPACITY	WHEELBASE
SMV 52-1200 C	52 tons at 1200 mm	6000 mm
SMV 55-1200 C	55 tons at 1200 mm	6000 mm



MODEL NAME	CAPACITY	WHEELBASE
SMV 15-1200 C	15 tons at 1200 mm	3750 mm
SMV 16-1200 C	16 tons at 1200 mm	3750 mm
SMV 18-600 C	18 tons at 600 mm	3750 mm
SMV 18-900 C	18 tons at 900 mm	3750 mm



MODEL NAME	CAPACITY	WHEELBASE
SMV 28-1200 B RoRo	28 tons at 1200 mm	4500 mm
SMV 32-1200 B RoRo	32 tons at 1200 mm	4750 mm



MODEL NAME	CAPACITY	WHEELBASE
SMV 60-1500 C	60 tons at 1500 mm	6000 mm
SMV 65-1200 C	65 tons at 1200 mm	6000 mm

## Empty container handlers

Single stacking  
3-6 high  
up to 8 tons



MODEL NAME	CAPACITY	WHEELBASE
SMV 3 ECC 80	8 tons at 1220 mm	3750 mm
SMV 4 ECC 80	8 tons at 1220 mm	3750 mm
SMV 5 ECC 80	8 tons at 1220 mm	3750 mm
SMV 6 ECC 80	8 tons at 1220 mm	3750 mm

Single stacking  
5-8 high  
up to 9 tons



MODEL NAME	CAPACITY	WHEELBASE
SMV 5/6 ECC 90	9 tons at 1220 mm	4500 mm
SMV 6/7 ECC 90	9 tons at 1220 mm	4500 mm
SMV 7/8 ECC 90	9 tons at 1220 mm	4500 mm

Double stacking  
4-8 high  
up to 10 tons



MODEL NAME	CAPACITY	WHEELBASE
SMV 4/5 ECC 100 DS*	10 tons at 1220 mm	4500 mm
SMV 5/6 ECC 100 DS*	10 tons at 1220 mm	4500 mm
SMV 6/7 ECC 100 DS*	10 tons at 1220 mm	4500 mm

\*DS = double-stacking spreader

## Laden container handlers

Low cabin  
3-4 high  
33-35 tons



MODEL NAME	CAPACITY	WHEELBASE
SMV 37 GC3-GC4	35/33 tons at 1490/1730 mm	5000 mm

High/mid cabin  
4 high  
33-35 tons



MODEL NAME	CAPACITY	WHEELBASE
SMV 37 GC4S	35/33 tons at 1490/1730 mm	5000 mm

Low cabin  
3-4 high  
41-45 tons



MODEL NAME	CAPACITY	WHEELBASE
SMV 45 GC3-GC4	43/41 tons at 1490/1730 mm	5500 mm
SMV 52 GC3-GC4	45/43 tons at 1490/1730 mm	6000 mm

High/mid cabin  
4-5 high  
41-45 tons



MODEL NAME	CAPACITY	WHEELBASE
SMV 45 GC4S-GC5S	42/41 tons at 1490/1730 mm	5500 mm
SMV 52 GC4S-GC5S	45/43 tons at 1490/1730 mm	6000 mm

Reach stackers for container handling, 10 to 45 tons



MODEL NAME	CAPACITY	WHEELBASE
SMV 108 TC6	10-8-5 tons	5000 mm



MODEL NAME	CAPACITY	WHEELBASE
SMV 2115 TC3	21-15-5 tons	5500 mm
SMV 2518 TC3	25-18-8 tons	5500 mm



MODEL NAME	CAPACITY	WHEELBASE
SMV 4127 TC5 (TC6)*	41-27-14 tons	6400 mm
SMV 4527 TC5 (TC6)*	45-27-14 tons	6400 mm
SMV 4531 TC5 (TC6)*	45-31-16 tons	6400 mm



MODEL NAME	CAPACITY	WHEELBASE
SMV 4535 TC5 (TC6)*	45-35-20 tons	6400 mm
SMV 4535 TCX5**	45-37-24 tons	6400 mm
SMV 4537 TC5	45-37-19 tons	6400 mm
SMV 4537 TCX5**	45-41-28 tons	6400 mm



MODEL NAME	CAPACITY	WHEELBASE
SMV 4542 TC5	45-42-24 tons	7250 mm
SMV 4542 TCX5**	45-44-30 tons	7250 mm
SMV 4543 TC5	45-42-25 tons	7500 mm
SMV 4543 TCX5**	45-44-34 tons	7500 mm



MODEL NAME	CAPACITY	WHEELBASE
SMV 4545 TC5	45-45-37 tons	8000 mm
SMV 4545 TCX5**	45-45-45 tons	8000 mm

Reach stackers for intermodal handling, 41 to 45 tons



MODEL NAME	CAPACITY	WHEELBASE
SMV 4123 CC5	41-23-9 tons	6400 mm
SMV 4527 CC5	45-27-13 tons	6400 mm
SMV 4531 CC5	45-31-16 tons	6400 mm
SMV 4531 CCX5***	45-33-20 tons	6400 mm
SMV 4533 CC5	45-33-16 tons	6400 mm
SMV 4533 CCX5***	45-37-24 tons	6400 mm



MODEL NAME	CAPACITY	WHEELBASE
SMV 4537 CC5	45-37-22 tons	7250 mm
SMV 4537 CCX5	45-40-28 tons	7250 mm
SMV 4538 CC5	45-38-23 tons	7500 mm
SMV 4538 CCX5***	45-40-32 tons	7500 mm



MODEL NAME	CAPACITY	WHEELBASE
SMV 4545 CC5	45-45-33 tons	8000 mm
SMV 4545 CCX5***	45-45-45 tons	8000 mm

Reach stackers for barge handling, 45 tons



MODEL NAME	CAPACITY	WHEELBASE
SMV 4542 TC4 BH	45-37-23 tons (yard)	7500 mm
	43-30-18 tons (barge)	7500 mm
SMV 4542 TCX4 BH**	45-41-31 tons (yard)	7500 mm
	45-37-26 tons (barge)	7500 mm
SMV 4545 TC3 BH	45-45-35 tons (yard)	9000 mm
	45-37-30 tons (barge)	9000 mm

Reach stackers for industrial handling, 35 to 80 tons



MODEL NAME	CAPACITY	WHEELBASE
SMV 4127	35-50 tons	6400 mm
SMV 4527	35-50 tons	6400 mm
SMV 4531	35-50 tons	6400 mm
SMV 4535	35-50 tons	6400 mm
SMV 4542	40-60 tons	7250 mm
SMV 4545	40-80 tons	8000 mm

\*TC5 = 5 high, TC6 = 6 high  
 \*\*TCX = Capacity with support jacks engaged  
 \*\*\*CCX = Capacity with support jacks engaged  
**Other models upon request**

# OPTIMA ENHANCED SPACIOUSNESS AND VISIBILITY

## Customized for your container handling needs.

When you step inside OPTIMA cabin, you find outstanding spaciousness and superior visibility. That makes operating the lift truck safe and efficient, along with valuable extra equipment.

The remarkable visibility is made possible by very large, lowered windows with no corner posts, thin but very strong roof crossmember, and curved panels. Sightlines to key working areas are clear both in the front, to the sides, and to the rear.

New EMC Master MD4 with 7" touch screen enables a more spacious cabin with its integrated solutions. There is also more space for operating the foot pedals.

The positioning of the instrumentation improves operating ergonomics. Instrumentation has been moved from the driver's left side to his right, above his seat, where it is conveniently accessible.

### 1 Remarkable visibility

You know great visibility when you see it. Sitting down in OPTIMA shows you what superior visibility means.

### 2 Electronic Machine Control, EMC Master

Full monitoring of all the vital components and functions on a MD4 7" touch screen. Programmable settings. CanBus technology increases engine and transmission reliability as well as hydraulics and joystick control.

### 3 Left armrest mini-steering options

Optional, ergonomic steering solutions that improve productivity.

### 4 Ergonomic instrumentation

Whatever extra equipment you need, we can install it as part of an ergonomic instrumentation layout. OPTIMA is truly spacious.

### 5 Comfort

An excellent seat, powerful cabin heating and ventilation, air conditioning – the driver is provided with every possible comfort.

### 6 Lifting levers or an electronic joystick

Depending on the truck, we offer lifting levers or an electronic joystick with auto accelerator/power control. All offer super-smooth touch control at every point of a handling operation.



### 3 Left armrest mini-steering options



Lever steering with return



Mini-wheel steering

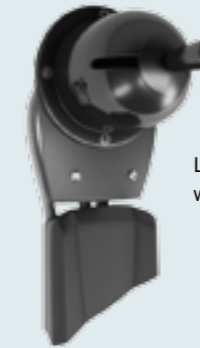

Lever steering without return



Remote control unit for rail and barge handling

# CABIN POSITIONING

## FORK LIFT TRUCK CABIN

Anti-slip steps and handles on both sides



Cabin can be raised 250–850 mm depending on model.

## EMPTY CONTAINER LIFT TRUCK CABIN



**Rear-mounted, low**  
Height 3900–4000 mm

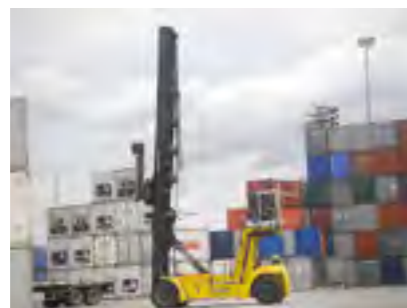

**Rear-mounted, high**  
Height 5100–5200 mm



**Front-mounted, low**  
Height 3660–4000 mm



**Front-mounted, high**  
Height 4500–4700 mm

## LADEN CONTAINER LIFT TRUCK CABIN

## REACH STACKER CABIN



**CC hydraulic sliding cabin**  
Stroke 2900/3300 mm



**TC hydraulic sliding cabin**  
Stroke 2900/3300 mm



**TC/CC elevating cabin RHS**  
Stroke 2850 mm



**Remote control unit EMC 133**  
For rail and barge handling





# RESEARCH & DEVELOPMENT HIGHLIGHTS

We are pushing forward heavy-duty lift truck technology with substantial R&D investment and a close connection to operating realities in the field. We are passionate about improving productivity, eco-efficiency and safety, and leave no stone unturned in doing so. Here are a couple recent technology introductions that make us unique in the heavy-duty lift truck business.

## HYBRID REACH STACKER: FIRST IN THE INDUSTRY!

Konecranes is offering the world's first hybrid reach stacker: the SMV 4531 TB5 HLT for container handling, with a lifting capacity of 45 tons. It features a hybrid diesel/electric driveline and hydraulic lifting system, and a super capacitor system for electrical energy storage. This innovative lift truck will cut diesel fuel consumption and emissions by up to 30% while offering improved performance in terms of acceleration and lifting response.

## Diesel fuel consumption reduced by up to 30%

The Konecranes hybrid reach stacker offers substantial cost and environmental benefits with reduced diesel fuel consumption of up to 30%. This is achieved by electrifying all flows of energy through hybridization of diesel and electrical technology across the driveline, the hydraulic lifting system and the electrical energy storage system.

Propulsion and lifting are powered by electric motors. The energy generated by braking and load lowering is recovered and stored for re-use later. This results in a substantial reduction in diesel fuel consumption and environmental impact. Meanwhile, productivity is increased in terms of quicker response and higher acceleration.

## Electrical energy storage

A traditional reach stacker has conventional batteries for starting the engine and powering the electrical systems including lights. The Konecranes hybrid reach stacker has a super capacitor system for energy storage that is connected to the truck's electrics. This system stores electrical energy that has been recovered for re-use later, and boosts the diesel-powered electrical generator at times of peak power demand.



## TRUCONNECT: SMART, CONNECTED LIFT TRUCKS

Konecranes TRUCONNECT is a suite of Remote Service products ranging from periodic data reporting to real-time diagnostics, technical support and monitoring. In order to deliver TRUCONNECT, Konecranes has connected data, machines and people. We provide you insights that allow you to optimize your lift truck's operations and activities.



Portal



Konecranes Remote Data Center



Modem

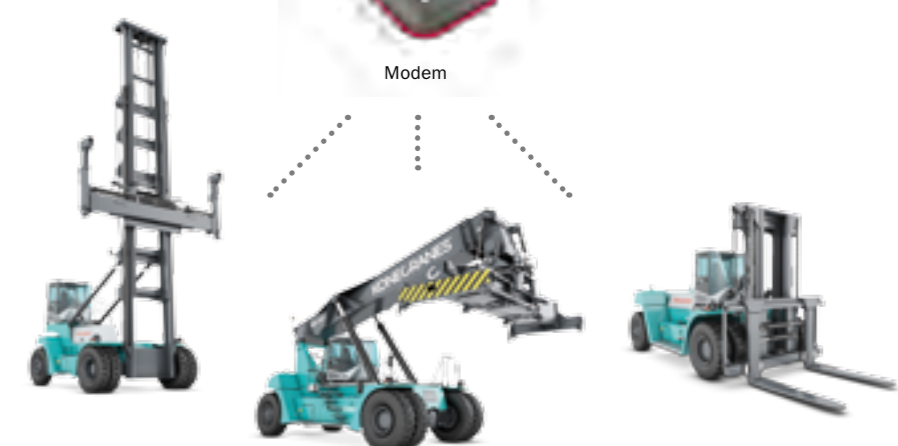

## Concrete data on your lift truck

TRUCONNECT Remote Monitoring uses sensors to gather usage data – running time, motor starts, work cycles and brake condition. Alert notifications of events such as emergency stops or over temperature, can be sent by SMS or email.

## All data in one system

All TRUCONNECT information is in the palm of your hand. You will get 24/7 access to our password protected customer portal for online views and reports. Aggregated data can quickly be viewed, analyzed and shared, for a single asset or an entire fleet.

## Optimize operations and maintenance

Remote monitoring is a key towards a more productive, efficient and safe workplace. With TRUCONNECT, you get more out of your lift trucks. It helps you optimize various aspects of your operations and maintenance.

- Lift truck utilization
- Productive profitability
- Safety planning
- Maintenance planning and prioritization
- Operator training

TRUCONNECT® can be retrofitted in Konecranes lift trucks delivered after 2005 with IQAN MDL.

# TOP TIPS FOR IMPROVING SAFETY

- ✓ **Start using our tire pressure management system.** Proper inflation of tires provides proper stability, allowing work at the rated maximum load. It improves safety. With under-inflated tires stability is reduced. You cannot work at the maximum rated load, and you should not use the truck at speeds over 10 km/h. Sharp cornering is dangerous. There is also the risk of tire explosion.
- ✓ **Start using our “transport mode” feature, available with Konecranes reach stackers and container lift trucks.** This feature prevents the operator from driving at full speed if the container is not in the correct driving position. This improves safety.
- ✓ **Start using the award-winning Konecranes NearGuard warning system.** It's based on Radio Frequency Identification Detection (RFID) technology. RFID receivers are mounted on the truck and RFID tags are attached to obstacles and/or employees working in the truck's operating area. When the truck is driven in close proximity to a tagged obstacle or employee, the operator sees a flashing warning indicator on the EMC control system's color display. NearGuard brings a powerful new dimension to lift truck safety and infrastructure protection.
- ✓ **Equip your lift trucks with our electronic scale, so your operators know the actual weight of what they're moving.** Your operators are alerted if the truck is overloaded, improving safety. An anti-overload system is standard with Konecranes reach stackers.
- ✓ **Start using our Fire Alarm and Suppression System.** We offer an effective fire alarm and suppression system that can be activated either manually or automatically.
- ✓ **Start using our Parking Distance Control (PDC) system.** It has sensors for driving in reverse. A similar system is employed in many automobiles.
- ✓ **Start using our Breath Analyzer.** This is an alcohol test unit which requires the driver to take a breath test before starting the truck.
- ✓ **Start using our Camera Supervision System.** It can be mounted as a reversing camera on the rear of the truck or as a forward camera mounted on the chassis or spreader.
- ✓ **Use EMC Master, Intelligent Electronic Machine Control.** Full monitoring of all the vital components and functions. Programmable settings. CanBus technology increases engine and transmission reliability.
- ✓ **Use drive speed limitations** during loading and unloading operations to increase safety.
- ✓ **Use additional LED and Xenon lights.** We offer a range of additional LED lights to increase visibility and make operations safer.





# HOW TO REDUCE TOTAL COST OF OWNERSHIP

- ✓ **Keep to preventive maintenance schedules** no matter how much operational pressure and temptation prevent you from doing so.
- ✓ **Use original Konecranes spare parts.** You might pay somewhat more for original Konecranes lift truck parts but they will more than pay themselves back in the form of truck reliability, performance and reduced hassle.
- ✓ **All Konecranes lift trucks are equipped with a load-sensing hydraulic system.** This system uses the engine power only as needed at each moment of the lift, based on the load and required lifting speed. It always provides power-on-demand. If you are driving and not lifting, the system turns off the oil flow. The result is reduced fuel consumption and reduced engine and drive train wear.
- ✓ **Use TRUCONNECT® Remote Monitoring and Reporting for Lift Trucks, a first in the industry.** TRUCONNECT® allows you to track the real usage of your trucks through a remote connection. It provides online views and reports containing information that will prove invaluable in efforts to improve fleet efficiency, productivity and safety.
- ✓ **Start using our tire pressure management system to reduce tire wear and save fuel.** Proper inflation of tires provides proper stability, allowing work at the rated maximum load. It extends tire life by as much as 25-50% and cuts fuel consumption by as much as 10-25%.
- ✓ **Extend the hydraulic oil change interval by using the Hydraulic Long Life (HLL) filter.** Using an HLL filter makes it possible to extend the recommended oil change interval from 4,000 running hours to 12,000 running hours. You save money and increase truck uptime while helping to preserve the environment. Meanwhile, the HLL filter helps to keep the entire hydraulic system clean: filtration particle size is max. 3 microns. It also reduces the amount of condensed water that gets into the oil tank. All of the hydraulic components work better with the HLL filter.
- ✓ **Start using the following fuel saving techniques and features:**
  - Reduce fuel, lubrication oil and filter consumption to extend the lifetime of the engine. Noise will also be reduced.
  - Use the "auto throttle" function to optimize engine speed settings.
  - Use the driving speed limitation function to limit the maximum driving speed to e.g. 15-25 km/h (unloaded) and to 10-20 km/h (loaded). These speeds are adjustable and programmable.
  - Use the automatic engine shut-down function. Limit idling time to 2-10 minutes (timer is programmable).
- ✓ **Start using the Konecranes EcoDrive module to monitor driving habits.** Use the EcoDrive fuel graph, running the engine in the green-to-yellow field only, and try to avoid the red field. The EcoDrive module records driving data so that trucks and drivers can be benchmarked and compared. It's an operational tool for training your drivers to operate your trucks in the most economical and environmentally friendly ways.
- ✓ **Konecranes reach stackers are equipped with auto-throttle.** Auto-throttle/automatic engine RPM increase (transmission in neutral) when the boom and/or spreader is being operated, maximizing productivity and optimizing fuel consumption. This smart feature is available for every Konecranes lift truck as an option: EMC 114 Electronic Servo Control.
- ✓ **Start using our "transport mode" function, available with Konecranes reach stackers and container lift trucks.** This function prevents the operator from driving at full speed if the container is not in the correct driving position, helping to minimize breakdowns and reduce wear and tear. The load distribution should be 1/3 on the two steering tires and 2/3 on the four drive tires.
- ✓ **Carry out annual inspections of your lift truck fleet.** It's a simple fact that preventive maintenance and repairs are much more cost-effective than post-breakdown maintenance and repairs. Konecranes offers an annual fleet inspection service that will maximize your fleet uptime over the long haul. It provides detailed reports on the status of each truck and expert recommendations for keeping your trucks running at peak performance.
- ✓ **Do you operate your trucks in a cold, hot or dusty climate?** If you work in a cold climate, start using our pre-heaters for the engine, transmission and hydraulics. If your trucks work in a hot environment, e.g. steel production, use our heat protection options. If it's a dusty environment, look into our filter options.

## IMPORTANCE OF TRAINING

We offer a portfolio of services to support you, including training. The importance of training can't be over-emphasized in minimizing safety risks and identifying and solving problems at an early stage. Our training programs help to develop and extend the competence of your operational and maintenance personnel, so you can keep your lift truck fleet performing at its best.

## TOTAL COST OF OWNERSHIP

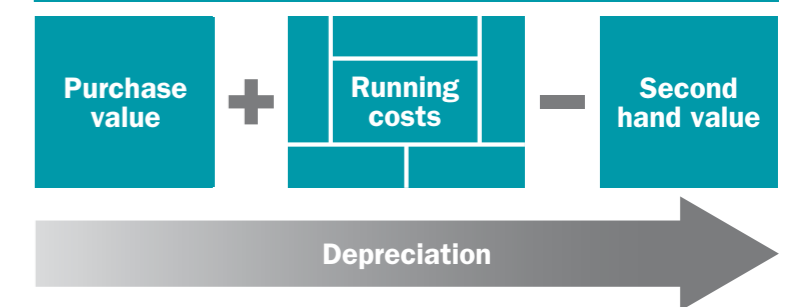

### RUNNING COSTS COMPRISE:

1. Cost of fuel
2. Cost of tires and rims
3. Cost of scheduled maintenance including lubricants, filters, grease and labor
4. Cost of wear and tear (consumables)
5. Cost of breakdown repairs
6. Cost of labor



**SATISFIED  
CUSTOMERS**

## The Port of Helsingborg **SERVING A CONTAINER AND INTERMODAL SPECIALIST**

More than 350,000 TEU (twenty-foot container equivalent unit) pass through the Port of Helsingborg every year. The Port's sea, road and rail operations are linked together by thirteen Konecranes reach stackers and a Konecranes fork lift truck.

In 1726 the Port of Helsingborg was just a 200-meter wooden pier stretching out into the Sound between Sweden and Denmark. Today it handles 8.4 million tons of cargo per year and 8.3 million ferry passengers. While cargo and passenger transport are important parts of its business, the Port of Helsingborg prides itself on being a container specialist. This is confirmed by the number of Konecranes reach stackers that ply the dock area, linking sea, road and rail transport together.

**"It's a pretty big machine, but it's incredibly smooth and easy to operate.** It turns on a dime and this is the most important thing from my point of view," says Göran Gustafsson who drives one of the SMV 4545 CBX5 reach stackers. Based in the port's Combi terminal, Gustafsson has been one of the drivers of these 110-ton machines since it was new in 2005. The Combi terminal is an area covering 40,000 m<sup>2</sup> with 3 km of railway track where about 50,000 containers and trailers are shifted between road and rail every year. With a lifting capacity of 45 tons up to three tracks away, this reach stacker has logged over 18,000 operating hours and made more than 235,000 lifts.

"On the railway side we must be able to reach across one track and pick up something from the one behind. This demands sturdy equipment," says Operations Manager Carl-Gustaf Nordin. Four reach stackers are assigned to the Combi



**"On the railway side we must be able to reach across one track and pick up something from the one behind. This demands sturdy equipment."**

Carl-Gustaf Nordin, Operations Manager





**“They are outstanding when it comes to service and spare parts. If an item is not in stock they will borrow one from the assembly line if they have to. This saves us a lot of money.”**

Mats Fernebrand, Purchasing Manager



terminal. They are all equipped with a combination attachment on the spreader, so they can handle both containers and trailers. Two of the machines feature a movable cabin – moved by hydraulics, basically a small elevator – that gives the operator extra visibility when needed. And if that isn't enough, they are also equipped with a special unit for remote control. “The operator can stand beside the reach stacker and control the boom from there. You don't need an extra helper when you pick up a trailer from the first track,” says Nordin.

**The Port of Helsingborg has a total of thirteen Konecranes reach stackers.** Nine of them are used mainly to load and unload trucks at the sea terminals, serving the tracked and mobile container cranes there. The Port's first Konecranes reach stacker was an SMV 4531 TA5, purchased in 2002. “Konecranes has become a business partner of ours. We cooperate very closely on these machines,” says Mats Fernebrand, Purchasing Manager. This involves continuous development of the features on existing machines, as well as feedback for the development of new models. Konecranes also trains the Port's own service technicians and gives occasional support during work peaks.

Fernebrand thinks it can be difficult to distinguish between premium lift truck suppliers if one looks only at technology. But there is one thing that definitely makes Konecranes a different lift truck supplier from the rest. He says he can call almost anybody in the company, knowing that the person answering will always do his or her best to help. “They are outstanding when it comes to service and spare parts. If an item is not in stock they will borrow one from the assembly line if they have to. This saves us a lot of money,” says Fernebrand.

It's his job to ensure that the Port of Helsingborg's equipment is ready to meet demand from shipping and forwarding companies. More than 1,500 freighters call at the port every year, moving approximately 180,000 TEU, while an additional 170,000 TEU pass by road and rail. There is no room for unplanned downtime.

**The Port of Helsingborg also handles goods that aren't containerized, so other lift trucks are needed.** The port uses a 16-ton Konecranes fork lift truck, type SMV 16-1200B, to handle containers that arrive filled with rolls of steel plate. It takes them to a warehouse for later distribution. The fork lift truck was purchased in 2011 with a long list of options added to the basic specification. Most of the options are related to safety and the environment: a fire extinguishing system, an alcohol lock, a tire pressure monitor with Bluetooth and a rear-view camera, for example. It also has a Scania diesel engine that complies with the European Union's Stage IIIB limits for emissions of nitride oxides and particulate matter.

**Left:** The SMV 4545 CBX5 reach stacker for intermodal handling can stack and lift 45 tons across all 3 rows.

## NTB North Sea Terminal Bremerhaven

# A LARGE EUROPEAN CONTAINER TERMINAL

NTB North Sea Terminal Bremerhaven GmbH & Co. is one of the largest European container terminals. It handles over 3 million TEU annually with links to 130 ports around the world. NTB serves about 45 ships per week in Bremerhaven, using six berths for large ships and a container yard of more than 1 million m<sup>2</sup>. About 200,000 empty containers are handled in the terminal every year.

### Requirements

NTB has strict requirements for its empty container handlers to ensure uninterrupted, high-performance handling. The goal is to serve larger container ships and a fast-growing volume of containers.

### Konecranes solution

NTB has been using Konecranes empty container handlers since 2004. They are high-capacity machines that are operated for up to 3,500 hours annually. NTB replaces the machines after four years of service and recently purchased a new 10-ton SMV 5/6 ECB 100 DS. The new machine has a very high handling speed, high availability, an ergonomic design, low fuel consumption, low noise levels and low service costs.

### What does NTB say?

“The new Konecranes empty container handler ensures high container handling productivity and makes further growth possible. Another good thing is that fuel consumption and emissions could be lowered, which is good for the environment and the climate,” says Thorsten Kosog, Technical Coordinator of NTB North Sea Terminal Bremerhaven GmbH & Co.

NTB handles about 200,000 empty containers annually. Their newest Konecranes empty container handler is an SMV 5/6 ECB 100 DS with a load carrying capacity of 10 tons, lifting up to 7 containers high. It can stack both single and double containers.





“The new Konecranes empty container handler ensures high container handling productivity and makes further growth possible.”

#### True 10-ton twin stacker

“The new empty container handler is particularly powerful thanks to its load carrying capacity of up to 10 tons and its high lifting and lowering speeds. It lifts up to 7 containers high and is fitted with a double-stroke frame which allows it to handle two empty containers at the same time, if necessary,” says Jens Uwe Meier of Konecranes Liftrucks in Bremen.

#### Low fuel consumption

Fuel consumption is kept low thanks to special load-sensing hydraulics. The driver's cabin provides excellent visibility over the entire operational area. It is also fitted with noise and vibration damping, a swiveling driver's seat and a heating and defrosting system.

Vital statistics	
Lift truck type	SMV 5/6 ECB 100 DS
Load carrying capacity	10 tons
Lifting gear	Duplex-standard
Lifting height	16.42 m
Height (unextended)	9.12 m
Height (extended)	16.89 m
Lifting speed	0.73/0.63 m per second (without load/with load)
Lowering speed	0.60/0.60 meter per second (without load/with load)
Engine	Scania DC 9-64 A with CanBus
Hydraulics	Parker Load Sensing System with variable pumping capacity for lower fuel consumption and reduced stress on motor and system components, joystick control
Cabin	Ergonomic with noise and vibration damping, heating and defrosting system, joystick control of lifting functions
Special features	Integrated, hydraulically adjustable spreader type Elme 584 with hooks and side clamps



Left: The SMV 5/6 ECB 100 DS can lift two containers at the same time with high handling speed, low fuel consumption and low noise emissions.



## BLG Logistics Group AG & Co. KG, Bremen

# INTERNATIONAL PROVIDER OF LOGISTICS SERVICES

The BLG Logistics Group, headquartered in Bremen, is an international provider of logistics services with subsidiaries and investments in 90 locations around the world. The Group specializes in automotive, contract and container logistics and employs more than 15,000 people worldwide.

WindEnergy Logistics, a division of BLG, established a warehouse in the Port of Bremerhaven in which it stores foundation elements for offshore wind energy plants. These elements are “tripods”, three-legged elements made of steel and weighing up to 900 tons. They are stored on concrete pads weighing 30 tons. The company needed special fork lift trucks for transporting them and placing them under the tripods.

### Requirements

WindEnergy Logistics was looking for special fork lift trucks with a low height profile and high load carrying capacity. They wanted high performance, low fuel consumption and the ability to operate on the ramps of Ro-Ro (roll-on, roll-off) ships. They also wanted particulate-free exhaust.

### Konecranes solution

Konecranes supplied its special SMV 32-1200 B Ro-Ro fork lift truck, and BLG became the first user of a Konecranes Ro-Ro fork lift in Germany. The lift truck has a very low height profile of 2.95 meters, a load carrying capacity of up to 32 tons, and excellent acceleration. It is specifically designed to provide efficient handling aboard Ro-Ro ships. It has a special Ro-Ro lift mast with freelif of 1550 mm and total lift of 3100 mm. In addition, its load-sensing hydraulics are ideal for handling “tripod” foundation elements and machine components. An Electronic Machine Control system, EMC Master, gives the driver real-time information on truck performance including full monitoring of the engine, transmission, hydraulics, alarms/errors etc.

The SMV 32-1200 B Ro-Ro is equipped with a high-power engine and a double-filter, double-exhaust system. The engine and transmission are controlled with CanBus technology which increases engine and transmission reliability.

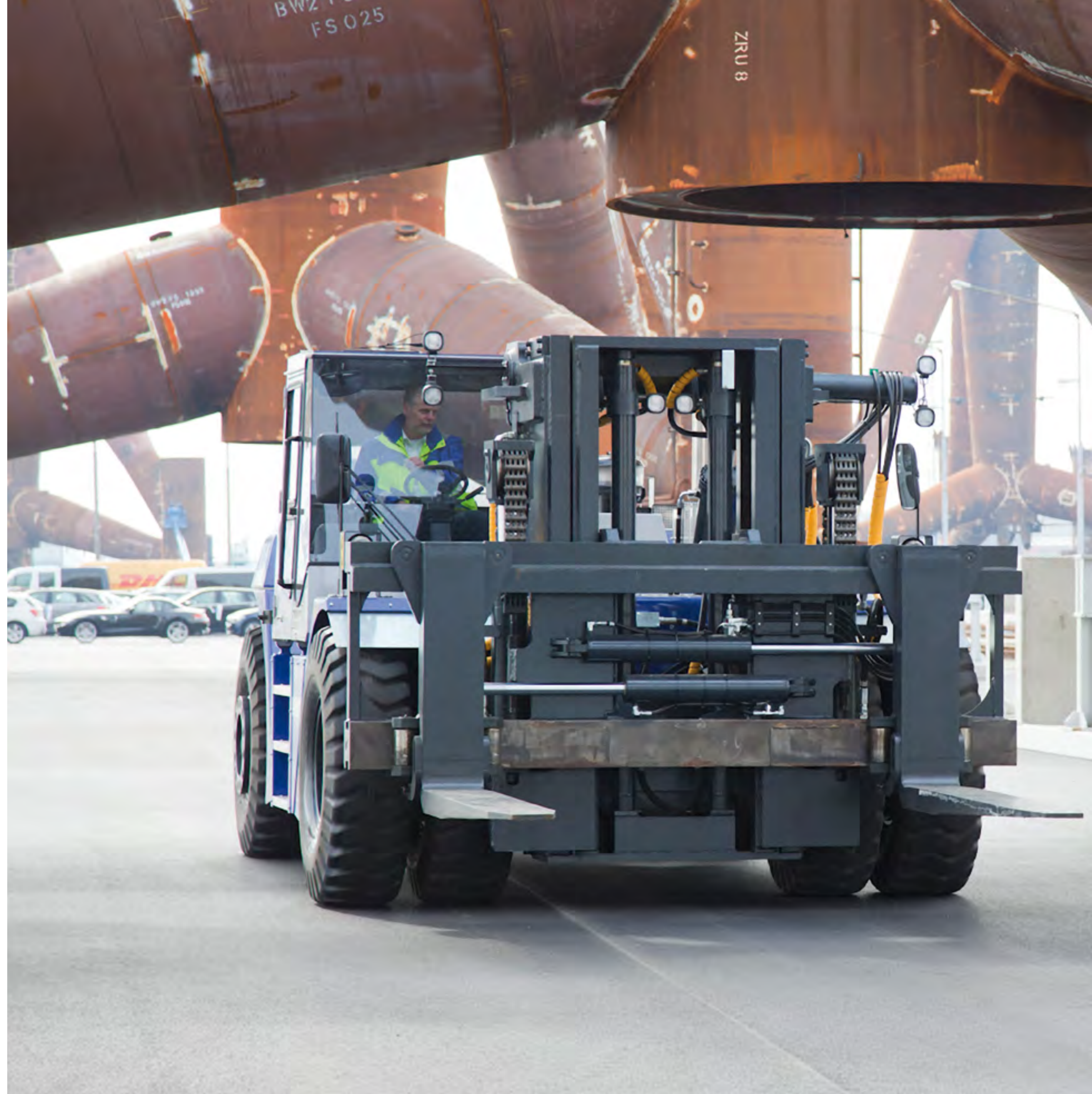



**BLG is the first company in Germany to use a Konecranes Ro-Ro fork lift truck.**



**Customer experiences 18 & 32 tons**

With the compact SMV 32-1200 B Ro-Ro, WindEnergy Logistics can drive safely under the tripods to place the concrete pads with high precision. Thanks to its double-exhaust system, the truck is eco-friendly and can be used in closed halls. With its excellent acceleration, the truck also provides efficient handling aboard Ro-Ro ships. BLG recently bought an SMV 18-900 B fork lift truck with duplex free lift of 3500 mm, built low to handle wind power components.

**What does the BLG Logistics Group say?**

“We already had very positive experiences with Konecranes reach stackers. The professionalism of the Konecranes team convinced us during this project as well. All our requirements and wishes were implemented with high precision and competence. Advice and support were exceptional. The new special fork lift truck is a high-quality product. We are very happy to be the first to use this special Konecranes fork lift truck in Germany. With its high load carrying capacity and power, it speeds up our production and logistics processes in the offshore terminal.”

Main technical data		
<b>Fork lift trucks</b>	SMV 18-900 B / Low	SMV 32-1200 B / Ro-Ro
<b>Capacity</b>	18 tons	32 tons
<b>Load centre (LC)</b>	900 mm	1200 mm
<b>Mast type</b>	Duplex freelif (low)	Duplex freelif (low)
<b>Freelif height</b>	1375 mm	1550 mm
<b>Max. lift height</b>	2750 mm	3100 mm
<b>Cabin height</b>	2905 mm	2925 mm
<b>Closed mast height</b>	3020 mm	2925 mm
<b>Carriage type</b>	Quick-change	Quick-change

## Weserport GmbH, Bremen

# INDEPENDENT PROVIDER OF PORT SERVICES

**Weserport GmbH is an independent port service provider and joint venture between the Rhenus Group (51%) and Arcelor Mittal Bremen GmbH (49%). In 2008, Weserport's four terminals in Bremen handled about 8.9 million tons of goods shipped by sea. With a turnover of 3.3 billion EUR, the Rhenus Group is one of the leading logistics service providers in Europe. The company has over 15,000 employees in more than 230 locations.**

Weserport's four terminals in Bremen's port district comprise over 330,000 m<sup>2</sup> of operating area. The company handles a wide range of goods shipped by sea: project cargo, steel products, forest products and many different kinds of bulk goods. The core business of goods handling is supplemented by freight services, clearance services and the organizing of complete transport chains.

Ships of up to Panamax size are loaded and unloaded on about 2 km of quays with a maximum draft of 9.45 m. Weserport is continuously expanding its range of services, evolving from a pure handling company to a total provider of port logistics services. The company is sending new cargo flows through Bremen and creating new departure possibilities. Weserport's terminals in Bremen are linked with important areas around the world via ports in Europe, North Africa, Turkey, Greece, the USA, Mexico and the Far East.





**“Konecranes stood out due to a good price-performance ratio. From the product perspective, the hydraulics gave clear advantages compared to the competition.”**

**What does Weserport say?**

“Konecranes was of course competing with other well-known lift truck manufacturers. Up to that point, we weren’t really considering trucks as investment goods. Konecranes stood out due to a good price-performance ratio. From the product perspective, the hydraulics gave clear advantages compared to the competition.”

**Customer experience**

“When buying a heavy-duty fork lift truck, what matters in addition to the technology is the lifecycle cost covering service, maintenance and repairs. A global network of service partners allows Konecranes to provide reliable and fast service with very committed employees. In the end, it was the total package that made us decide: the technical possibilities offered by the fork lift trucks and the first-class support through a regional service partner. The trucks are serviced by Willenbrock, whose work is excellent.”

**What Konecranes delivered**

Weserport uses four Konecranes heavy-duty fork lift trucks:

- 3 x SMV 45-1200 B (maximum load 45 t)
- 1 x SMV 52-1200 B (maximum load 52 t)

Load handling includes multi-function:

- Forks
- Forks with magnet
- Coil rams



**Paterson Simons & Co. (Africa)  
Limited and Konecranes**

# LIFTING GHANA TO GREATER HEIGHTS

**Paterson Simons & Co. (Africa) Limited has a well-earned reputation in Ghana as a company that takes good care of its customers. Konecranes and Paterson Simons/Pasico make a strong team: Konecranes as manufacturer of lift trucks, and Paterson Simons/Pasico as distributor of Konecranes lift trucks. The two companies have many values in common and always pay careful attention to customer needs.**

Ghana's economy is booming. Oil was discovered a few years ago, and Ghana looks set to become a key player in the energy industry. Gold has been a staple Ghanaian export for decades. Ghana is also the world's second-largest producer of cocoa, which along with other agricultural products like rice, nuts, and timber, contributes to a GDP that has almost quadrupled since the turn of the century. Ghana's ports are essential for the country's present and future prosperity, being the hubs of the country's import and export activities.

**Enter Paterson Simons/Pasico**

Paterson Simons & Co. (Africa) Ltd., based in the UK, was founded in 1948. Its subsidiary, Pasico Ghana Ltd., was founded in Ghana, also in 1948. The original business was based on building materials and general trade. As time passed, it added mobile hydraulic equipment to its product range. Paterson Simons/Pasico started to distribute Konecranes lift trucks exclusively in 2002. To date, the company has sold over 200 Konecranes lift trucks across West Africa. Paterson Simons/Pasico is known for selling high-quality equipment and backing it up with friendly, high-quality service.





**Ghana Ports and Harbours Authority (GPHA)**

Ghana Ports and Harbours Authority (GPHA) has the most important role in managing Ghana’s ports, operating across all of Ghana’s major ports along its 539 km of coastline. Richard A. Y. Anamoo, Director General of the GPHA, is justifiably proud of the organization he heads. For over 25 years, Mr. Anamoo has worked in various capacities in GPHA, from Port Civil Engineer to Project Engineer and Chief Engineer. He is now both Director of the Port of Tema and Director General of GPHA, and his long experience means he has a deep understanding of every level of GPHA’s operations.

GPHA wanted to deal with a well-established and reliable company when buying its container handling equipment. Purchasing steadily from Paterson Simons/Pasico since 2002, GPHA has built up a fleet of 20 Konecranes fork lift trucks and 35 Konecranes reach stackers.

From the 10-ton SMV 10-1200 B up to the 32-ton SMV 32-1200 B RoRo, GPHA uses its Konecranes fork lift trucks mainly for general cargo handling. The Konecranes reach stackers are principally used for quayside operations, especially vessel unloading and moving containers ready for devanning. GPHA mainly has 45-ton models such as the SMV 4535 TB5, but keeps a few 10-ton SMV 108 TB6s on hand for empty containers.

Stephen Owiah, Port Mechanical Engineer at GPHA Tema Port with substantial experience working across Ghana’s major ports, knows these Konecranes lift trucks well. They are operated around the clock, so Mr. Owiah is pleased that visibility from the cab at night is very good. Safety is always a top priority, so he also likes the Konecranes advanced safety features. “Speed limiting due to load on the boom – that is excellent,” he said. Overall, he is very satisfied with the equipment: “It is extra reliable.” He added that the overall design and compact size makes it easy to use, and is particularly impressed with the automatic lubrication on the chassis, which reduces the amount of time needed for maintenance and keeps things working continuously when schedules are tight.

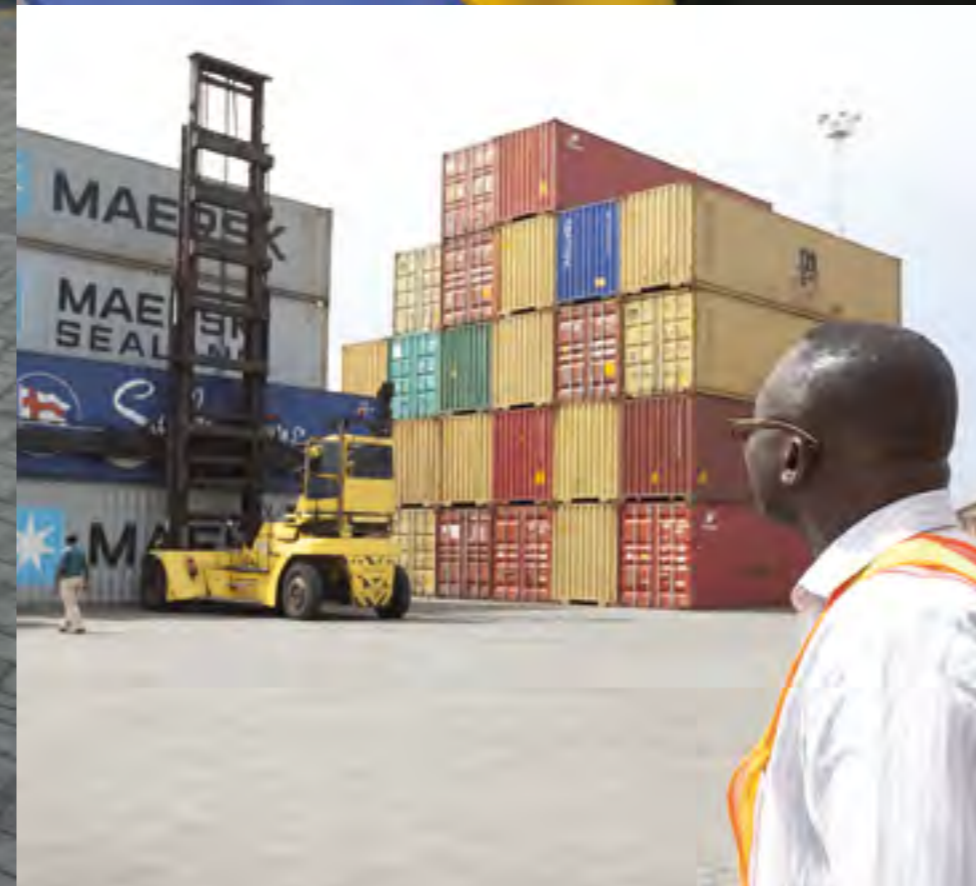

**“It is extra reliable.”**

Stephen Owiah, Port Mechanical Engineer, Tema Port

**Left:** Golden Jubilee Terminal, Port of Tema.

**Top right:** Mr. Richard A.Y. Anamoo, Director General of Ghana Ports and Harbours Authority.

**Bottom right:** Port Engineer Stephen Owiah watches an SMV 7/8 ECB 90 empty container handler in action.



**“We greatly value our long-standing partnership with Konecranes. Great products. Great people.”**

Henry Lyne, Paterson Simons/Pasico

**Port of Tema**

About half an hour's drive east of the Ghanaian capital Accra, you find the industrial town of Tema and the Port of Tema. Originally a fishing village, the port started operations in 1962 and is now the busiest and biggest seaport in the country, handling over 10 million metric tons of cargo every year.

The Port of Tema's Golden Jubilee Terminal was commissioned in 2007 to reduce congestion at the main terminal when the volume of containerized imports and exports outgrew the original port. It provides modern facilities for the receiving, storage, and forwarding of cargo, working as an off-dock devanning terminal. Golden Jubilee can handle up to 250 containers per day when working at full capacity.

This is an excellent place to observe how a well-run container terminal works. Everything is extremely well-organized, down to the very last detail. The Terminal Operating System knows where every container is at any given moment. Container movement is carefully scheduled so that devanning is efficient: containers stay in the port for the minimum amount of time. Empty containers are stacked in a storage area, ready to be re-filled with exports and taken back to sea.

Evans Mensah, Engineering Superintendent at the Golden Jubilee Terminal, described how GPHA customers really like the service at Golden Jubilee, not only because the terminal is very efficient, but because they know their cargo is safe. “Our security is very good,” said Mr. Mensah.

**Left:** The Konecranes SMV 4531 TB5 reach stacker is very good in a tight space.

**Top right:** Forklift operator Edmund Odoi Abbey likes using Konecranes fork lift trucks.



**“Work is much faster and safer.”**

Jacob Adorkor, Acting Director of Port, Tema Port

**Port of Takoradi**

In order to get a full picture of the GPHA’s operations, we now visit the Port of Takoradi on Ghana’s west coast. It opened in 1928, and today it is the second-busiest port in Ghana. Recently, it has been expanding its cooperation with developing resource areas, being close to gold, mineral, and oil production. It is also an important center for cocoa export. New facilities for storage and bulk handling should be completed over the next three years to service a growing volume of ship traffic and fast-expanding railway links to nearby mining areas.

Jacob Adorkor, Acting Director of Tema Port, explained how expansion has increased the need for lifting equipment. Part of the GPHA Konecranes truck fleet is used here, and Takoradi port recently ordered four more reach stackers. The volume of materials passing through the port today is over five times greater than what it was barely six years ago.

They were using a crane with a spreader before they bought some reach stackers. Mr. Adorkor said the new equipment has completely changed the way the drivers do their work, making it both faster and much safer. He liked the flexibility and maneuverability of the Konecranes reach stackers in small spaces, and was very impressed with their ability to “reach over a three-high stack of containers and get in behind”.

George Frederick Barnes, the Port Mechanical Engineer, said that Konecranes was chosen through Paterson Simons/Pasico because the trucks fulfilled their technical requirements. Since using them, he has noticed “they are especially stable and reliable in their performance”. The Principal Port Mechanical Engineer, Ben Klu, agreed and added: “The after-sales service is good with Pasico”.



**Top left:** The 45-ton SMV 4531-TB5 (left), a big machine for big loads, and its smaller cousin, the 10-ton SMV 108 TB6 (right) for empty container handling.

**Top right:** Jacob Adorkor, Acting Director of Port, Tema Port.

**Bottom:** Unloading ships in Takoradi has become easier with the Konecranes reach stackers.





**“Very easy to maneuver and correct.”**

Ben Otu-Laryea, Assistant Workshop Manager at AngloGold Ashanti in Iduapriem



**Tullow Oil and Kosmos Energy**

Offshore oil has brought exciting new prospects to the Ghanaian economy. In Takoradi, the Tullow Oil storage facility is located next to the local airport. It contains hundreds of drilling pipes of various sizes, ready for transport to the new oil rigs.

Crane rental company Mobicrane has rented out some Konecranes fork lift trucks to Tullow to move the pipes, made of heavy steel in order to withstand the pressure of being kilometers under the sea and under the ground.

The Plant Manager, Major Attike, introduced his drivers, who were full of praise for Konecranes fork lift trucks. They said that the controls are “excellent – intuitive and simple” to use, the truck has “good overall visibility”, and its compact size and small turning circle makes it “easy to maneuver” in the tight spaces of the crowded storage yard.

At another yard, where they handle materials and equipment for energy company Kosmos, the drivers had a similar opinion. When we asked fork lift operator Edmund Odoi Abbey what he liked about the Konecranes fork lift, he smiled and said: “Perfect”.

**AngloGold Ashanti**

AngloGold Ashanti has a number of gold mines in Ghana including the gold mine in Iduapriem, some two hours north of Takoradi, in the western mining area. Before independence, Ghana was called the Gold Coast, and here it’s easy to see why. The mine is very profitable: in the first quarter of 2012, it produced 45,000 ounces of gold. As you would expect, security is tight, and all visitors are checked on their way in and out.

AngloGold Ashanti uses a Konecranes 10-ton SMV 10-1200 B fork lift truck to carry large amounts of supplies. The purchase decision was made after receiving recommendations from other companies operating Konecranes lift trucks, and after seeing a Konecranes fork lift truck in action at a workshop. AngloGold’s fork lift is always in demand, so they are considering buying more soon.

Ben Otu-Laryea, the Assistant Workshop Manager, is very pleased with its performance: “We bought it in 2008. We use it a lot and it is still running well,” he said. “It is very easy to maneuver and correct when the load is not straight.”

**Ghana’s gleaming future**

Ghana is a special place. With its abundant natural resources, friendly and hard-working people, and welcoming climate, Ghana has already achieved much. Its busy, expanding ports are serving a healthy volume of trade and a growing level of prosperity that is fast bringing the country into the twenty-first century and beyond.

In cooperation with Paterson Simons/Pasico, Konecranes looks forward to participating in Ghana’s continuing success.

**Left:** Driver’s view on the way to move some oil pipes at Tullow Oil.

**Top right:** The Konecranes SMV 10-1200 B forklift unloads supplies for the Iduapriem mine.

**Bottom right:** Assistant Workshop Manager Ben Otu-Laryea (left) described the fork lifting needs of the Iduapriem mine.

## Gränges Sweden AB, Finspång, Sweden

# TOUGH TRUCKS, SOFT TOUCH

**With over 400 years of metalworking experience and history, Gränges Sweden AB faces unique challenges. Twelve customized fork lift trucks from Konecranes seamlessly connect the company's past, present and future for more efficient production and improved safety.**

Founded in 1580, the Gränges factory in idyllic Finspång, Sweden has a long history in metalworking. Cannons produced at the site were used as far afield as the American Revolutionary War. So it's safe to say they know what they're doing at this sprawling, 120,000 square meter production site, which today specializes in the production of aluminum strips for heat exchangers, mainly for the automotive industry. In fact, the company holds an impressive 14% of the global market in this segment and has its sights set on even more.

**In recent years, Gränges has made strategic investments** to ensure the highest levels of safety, improve quality, and make production more efficient. Of course, integrating cutting-edge technology and a centuries-old production facility presents a number of special challenges, not least when it comes to lift trucks. At first Gränges tested electric fork lift trucks, but they proved unable to handle the pace of production. They needed a better solution fast. "Konecranes was the clear choice. No other company could meet all of our specific needs," asserts Rolf Andersen, Truck Coordinator, who's been making sure that the company's lift trucks are safe and working well since 2009.

Gränges had many requirements but three were "must-have": excellent maneuverability combined with high lifting stability, reliability in constant use, and safety/ergonomics. The twelve 10-ton Konecranes fork lift trucks busily crisscrossing the facility today prove that Gränges found its answer.

"Our aluminum casting, rolling, and finishing are carried out across a large production infrastructure that's been here for hundreds of years," explains Andersen. "To maneuver around buildings through narrow roads, we need trucks with a much shorter wheelbase than normal."





**“Even with a shorter wheelbase, these are stronger and more stable than other trucks. I feel completely secure lifting anything I need to lift.”**

Viktor Kjellander, Driver

**With their tailor-made 2,800 mm wheelbase,** Gränges Konecranes SMV 10-1200 B fork lift trucks fit easily wherever they need to go. Thanks to a 5-ton counterweight added to the back of the sturdy, box-type chassis, these trucks can handle their daily loads with ease. “Other trucks practically threw me on my nose sometimes. That never happens with our trucks now,” says Andersen. “I mean, how many people put a 16-ton upright mast on a 10-ton truck? Yet it’s still more stable and secure, by far, than any other truck we’ve had.” Driver Viktor Kjellander agrees: “Even with a shorter wheelbase, these are stronger and more stable than other trucks. I feel completely secure lifting anything I need to lift.”

The powerful, low-emission Volvo TAD 660 VE engines provide the much-needed reliability for Gränges demanding production schedules. “We run practically 24/7, and we drive at 98% max. capacity all the time. The trucks in our rolling mill log about 5,000 hours per year,” explains Andersen. “It’s extremely important for us that our trucks are rolling all the time,” confirms Anna Stenlund, Communication Manager for Gränges.

**It’s also important for Gränges that these tough trucks** can handle the most delicate materials. Each aluminum coil can weigh anywhere from 8 to 12 tons. Meanwhile, some of the coiled aluminum strips are a mere 0.05 mm thick. They need to be handled very carefully in the midst of a fast-paced production environment. The coils are valuable. “I tell our drivers that damaging one of these coils is like damaging a brand new car,” shares Stenlund. The auto tilt-to-zero feature in the lift mast minimizes costly damage to the material during offloading. According to Andersen, it does a better job than a driver can do manually and it’s more secure.

The forks themselves are also specially designed, with tapering starting 500 mm from the tip to allow the trucks to carry standard pallets for other daily tasks such as transporting scraps – adding valuable flexibility.



**Driver Viktor Kjellander:** Viktor has driven trucks of various brands for Gränges during his two years with the company and currently works exclusively with the Konecranes SMV 10-1200 B. “The trucks are very flexible — it’s great to be able to use the same truck for a lot of different tasks. And the cameras are placed well so you don’t have to turn your head as you’re maneuvering, no matter what you’re doing.”



**“I tell our drivers that damaging one of these coils is like damaging a brand new car.”**

Anna Stenlund, Communication Manager



**When deciding what truck brand and model to purchase,** Gränges assembled an extensive internal work group that determined the truck requirements. This work group included members of the company’s industrial health service team. “We work with a safety-first philosophy. Ergonomics are key, not only for everyone’s well-being, but also for boosting productivity,” says Andersen. The finished requirement list was lengthy, detailed and unique. For example, at the rolling mill, the aluminum is heated to 500 degrees Celsius during hot rolling. When the driver picks up a load, it can be as hot as 350 degrees. This consideration, combined with the requirement of constant operation, led to the addition of strategic ventilation in the cabs, fire-proof hoses, and a semi-automatic fire extinguishing system that uses a water-based formula to smother fire inside the cab.

**Konecranes built a long list of special features** into the SMV 10-1200 B fork lift trucks for Gränges, including personalized USB keys for each driver to log all driving statistics, integrated alcohol breath analyzers, an auto function which prevents use of the computer while in gear, rotating RoTo driver seats for added visibility, extra brake lights at eye level, reverse distance control, adjustable driver speed limits, and additional steps for a more natural climb into the cab. Even the specially ordered yellow body color is designed to increase safety.

When asked what the greatest advantage is in selecting Konecranes fork lift trucks, Andersen doesn’t hesitate: “It’s in getting quality trucks customized to our each and every need.”

Vital statistics	
Company	Gränges Sweden AB
Product	Rolled aluminum strips for brazed heat exchangers
Location	Finspång in the Östergötland region of Sweden
Year of founding	1580
Ownership	Part of Sapa Holding AB, 100%-owned by Norwegian company Orkla ASA
Number of employees	470
Annual turnover	Around 267 million € (SEK 2,200 million)
Exports	85% of tonnage produced
Lift trucks used	12 Konecranes SMV 10-1200 B fork lift trucks

**Driver Mikael Lachan:** Mikael started working for Gränges this year in a summer job, getting his start in lift truck driving with the 10-ton Konecranes SMV 10-1200 B fork lift truck after extensive fork lift training.

“The most complicated thing is getting a feel for the size of the vehicle. But learning to operate it isn’t complicated, and it feels completely stable. You can hardly tell you’re lifting something. It doesn’t feel like anything’s there. The cameras make it easy to see and maneuver, and getting orders through the PC makes it easy to know what you’re supposed to be doing.”



**LIFT TRUCKS  
FOR EVERY  
APPLICATION**

# CONTAINER PORTS AND TERMINALS

Konecranes is a heavy-duty lift truck generalist, with the ability to expertly serve a very wide range of applications. That said, container handling is a special application that we serve with special expertise. Our offering for container handling comprises container lift trucks, reach stackers, fork lift trucks and all the attachments needed.

At Konecranes we believe that repeat business is the truest measure of customer satisfaction. Many important container ports are Konecranes Lift Truck customers, returning to us again and again when the time comes to renew or upgrade their lift truck fleets. It's a sign that we are doing some important things right in the areas of truck performance, productivity, service and total cost of ownership.

### Exactly the lift truck you need

If the container handling business is about effortlessly answering the customer's question "What have you done for me lately?" then the same is true for us when we serve you. It starts with getting exactly the lift truck you need — the one with the right performance, combination of standard and optional features, and attachments.

We offer the widest and deepest range of premium lift trucks for container handling on the market. You will find the model you need, optimized to your specific requirements for a long, strong and lean service life.

### Transport and logistics

If you are a transport and logistics company operating a container terminal or warehousing/expediting services, we have an excellent offering for you that includes heavy-duty fork lift trucks and special attachments. Do you have a specialization? What do you need to lift and move? We probably have experience with your specialization and can offer a proven solution.



**REACH STACKERS FOR CONTAINER HANDLING 10 – 45 TONS**  
We offer the widest and deepest range of reach stackers for empty and laden container handling in container ports. You will find the capacity/performance ratio and feature list you need in our range.



**EMPTY CONTAINER HANDLERS 8 – 10 TONS**  
Konecranes empty container lift trucks offer a very fast total operating speed as a function of lifting, lowering and driving speed. Our range has mid-mounted and rear-mounted cabins and excellent stability.



**LADEN CONTAINER HANDLERS 33 – 45 TONS**  
Konecranes laden container lift trucks offer a fast total operating speed (lifting + lowering + driving speed). The ratio of lifting capacity to truck size and length is best-in-class. These heavy-duty top-loaders are very stable and still compact.



**FORK LIFT TRUCKS FOR SPECIAL HANDLING 10 – 65 TONS**  
We offer a wide range of fork lift trucks with special attachments for miscellaneous handling such as moving broken containers, moving flat racks, and loading/unloading trucks.



**CONTAINER LIFT TRUCKS** for empty and laden container stacking operations requiring flexibility and speed.



**REACH STACKERS** for empty and laden container stacking operations requiring flexibility and speed. Lowest investment cost and stacking density.



**STRADDLE CARRIERS** for container terminals with straddle carrier-based operations. High performance, safety and lifecycle value.



**RUBBER TIERED GANTRY (RTG) CRANES** for medium-sized to large terminals. Excellent operational flexibility; ability to change stacks. High productivity thanks to Konecranes Active Load Control technology.



**RAIL MOUNTED GANTRY (RMG) CRANES** for intermodal container terminals. High productivity thanks to Konecranes Active Load Control technology.



**AUTOMATED RAIL MOUNTED GANTRY (ARMG) CRANES** for large container terminals with room for expansion. Linked to, and controlled by, Terminal Operating System (TOS). High productivity thanks to Konecranes Active Load Control technology.

## BUYER'S GUIDE

WHAT'S THE RIGHT CONTAINER HANDLING EQUIPMENT FOR YOUR YARD?

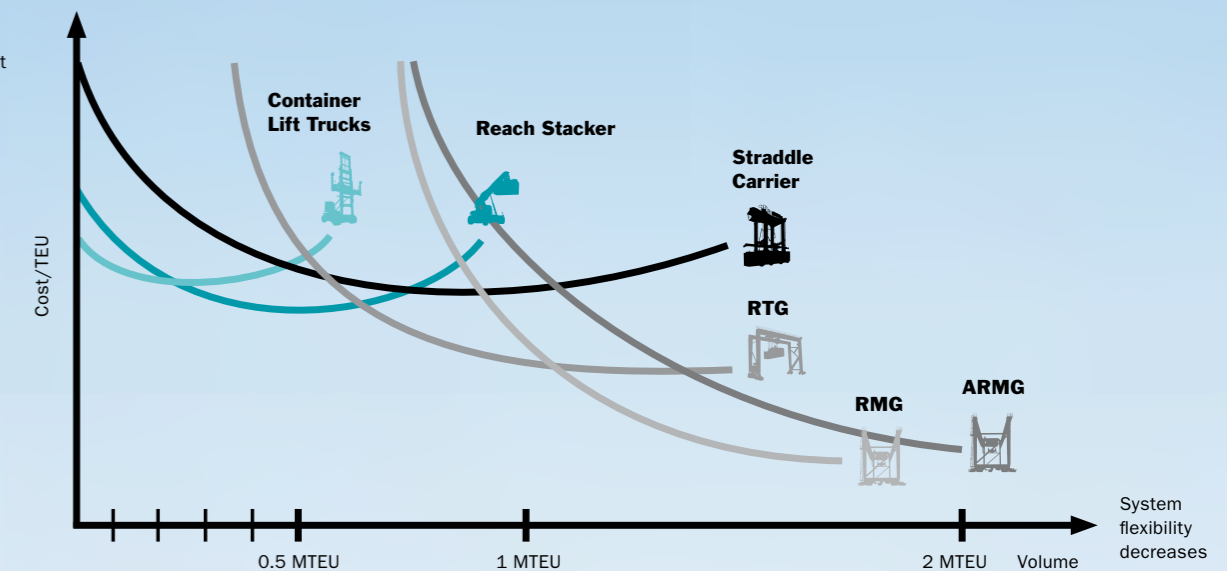

- Cost/TEU is changed by additional investments
- Achievable cost/TEU is dependent upon technology
- The technology selected may restrict future evolution, e.g. to automation



**KHALIFA PORT IN ABU DHABI** operates a large fleet of Konecranes Automated Stacking Cranes (ASCs) and three Konecranes reach stackers, model SMV 4531 TB5, lifting capacity 45 tons. They are used to handle oversized cargo, special containers, and to load/unload trucks outside the ASC stacks. They are equipped with safety features such as safe transport mode, reverse alarm, and extra lights. Operational features include EMC Master electronic control, a container counter and extra-strong air conditioning. Maintenance features include central lubrication and wheel nut protection.

# INTERMODAL AND BARGE HANDLING

**Konecranes provides a wide range of reach stackers, fork lift trucks and attachments for intermodal and barge container handling. Their versatility, reliability, maneuverability, speed and cost-effectiveness have made them a popular choice with leading intermodal terminal operators and rail transport companies.**

Konecranes has been serving demanding intermodal customers for decades with Rail Mounted Gantry Cranes (RMGs) and heavy-duty lift trucks specially adapted for this demanding environment. Our RMGs and intermodal reach stackers are known for their reliability and high productivity.

With Konecranes intermodal lift trucks you can achieve turnaround times that are both very fast and very reliable, pleasing your customers and earning their long-term business. You also improve the utilization of your lift trucks, because you can reduce the slack in their schedules.

## The perfect intermodal lift truck?

If you were to describe the perfect lift truck for intermodal operations, what would you say? Big and powerful, able to operate over at least three rails, yet very maneuverable. A long list of standard features. An even longer list of optional features, so you can build the truck you need down to the smallest detail. Maximum reliability. Excellent performance. A cabin that your drivers like, giving excellent visibility in all directions. The lowest Total Cost of Ownership over the long-term. Some of the world's leading intermodal operators have gone through this kind of selection process, ending up with Konecranes.



**INTERMODAL HANDLING IN THE PORT OF HELSINGBORG**, with 4 rail tracks 650 m long and 2 rail tracks handled from both sides. This big stacker lifts 45 tons across all three container rows and both rail tracks. It has an elevating cabin and can be controlled remotely.



**THE BIGGEST REACH STACKERS IN THE WORLD** for barge loading of containers and other cargo, with an outreach 3 containers wide. This truck can do yard stacking and load railcars and river barges – 3 functions in 1 truck. Very high lifting capacities.



**SOMETIMES IT'S BEST TO GET OUT OF THE CAB** to see things from the ground. We offer a remote control unit for rail and barge handling.



**THIS REACH STACKER DOES BARGE CONTAINER HANDLING** at the Terminal de Seine in Paris. It has a movable cabin that gives the driver good sightlines and a spreader with overheight folding legs.



**KONECRANES INTERMODAL REACH STACKERS** are surprisingly smooth, easy to operate and maneuverable despite their size. They have a tight turning radius and a lifting capacity of 45 tons up to 3 tracks away.

# SPREADERS

For container handling and intermodal handling

## Empty handling attachments



**EMPTY CONTAINER LIFT TRUCK ATTACHMENT**  
**ELME 588-TB single stacking spreader**  
 Telescopic sidelifift spreader for empty ISO containers with lifting capacity up to 10 tons.



**EMPTY CONTAINER LIFT TRUCK ATTACHMENT**  
**ELME 582-LS double stacking spreader**  
 Telescopic sidelifift spreader for single and double stacking of empty ISO containers with a lifting capacity up to 10 tons.



**EMPTY CONTAINER LIFT TRUCK ATTACHMENT**  
**ELME 584-LB double stacking spreader**  
 Telescopic sidelifift spreader for single and double stacking of empty ISO containers, with lifting capacity up to 10 tons.

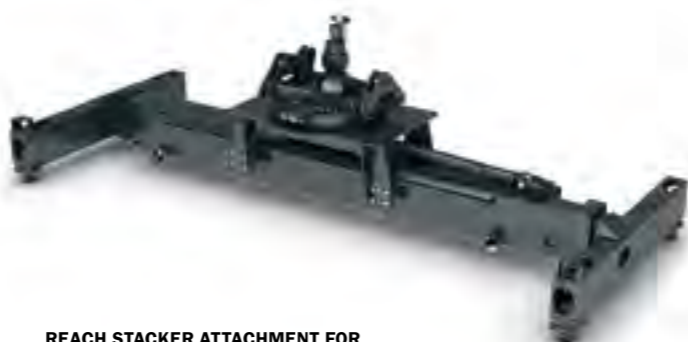

**REACH STACKER ATTACHMENT FOR EMPTY CONTAINER HANDLING**  
**ELME 517-MPS**  
 Telescopic spreader for empty ISO containers with lifting capacity up to 10 tons.

## Laden handling attachments



**LADEN CONTAINER LIFT TRUCK ATTACHMENT**  
**ELME 818 gantry-type spreader**  
 Telescopic toplift spreader for laden ISO containers with lifting capacity up to 45 tons.



**FORK LIFT TRUCK ATTACHMENT**  
**Container spreader with inverted forks and fork shafts**  
 Other types and combinations are available.



**REACH STACKER ATTACHMENT FOR LADEN CONTAINER HANDLING**  
**ELME 817-MPS/PPS with mechanical or hydraulic pile slope**  
 Telescopic spreader for laden ISO containers with lifting capacity up to 45 tons.

## Overheight cargo and flat racks



**REACH STACKER ATTACHMENT FOR LADEN CONTAINER HANDLING**  
**ELME 817-MPS/OFL**  
 Telescopic spreader with overhead folding legs for open-top containers and flat racks with extra high cargo. Flat racks often have overheight cargo that must be lifted like this.

## Combi handling of containers and trailers



**REACH STACKER ATTACHMENT FOR INTERMODAL HANDLING**  
**ELME 857-PPS**  
 Telescopic intermodal spreader (combi/piggyback) for laden ISO containers, swap bodies and trailer handling. Lifting capacity up to 45 tons (in twistlocks and lifting legs).



# STEEL AND ALUMINUM

No two steel mills or aluminum production facilities are alike. The heavy-duty cranes and lift trucks always need to be specially designed for the places in which they are used. Whether you need a crane to move raw materials or hot metal, or to shape products in the rolling mill, we provide cranes adapted to their specific location and role in your facility. The same is true of our lift trucks. We offer a wide and deep range of heavy-duty lift trucks for steel and aluminum production, along with a complete range of special attachments.

## Fork lift trucks 10–65 tons

Konecranes fork lift trucks provide a fast and efficient means of moving steel and aluminum products around your warehouse and out to the customer. Our fork lift trucks have a tight turning circle and excellent maneuverability, combined with a strong lifting mast and easily adaptable, heavy-duty forks. You'll find the right fork lift truck for your operation in our range.

## Reach stackers 10–80 tons

Konecranes reach stackers are ideal for moving heavy steel or aluminum products around storage areas where space is limited, or the weight exceeds what a fork lift truck can handle. Electronic overload protection helps to keep your products, storage facility and drivers safe. We offer a complete range of attachments for industrial handling.

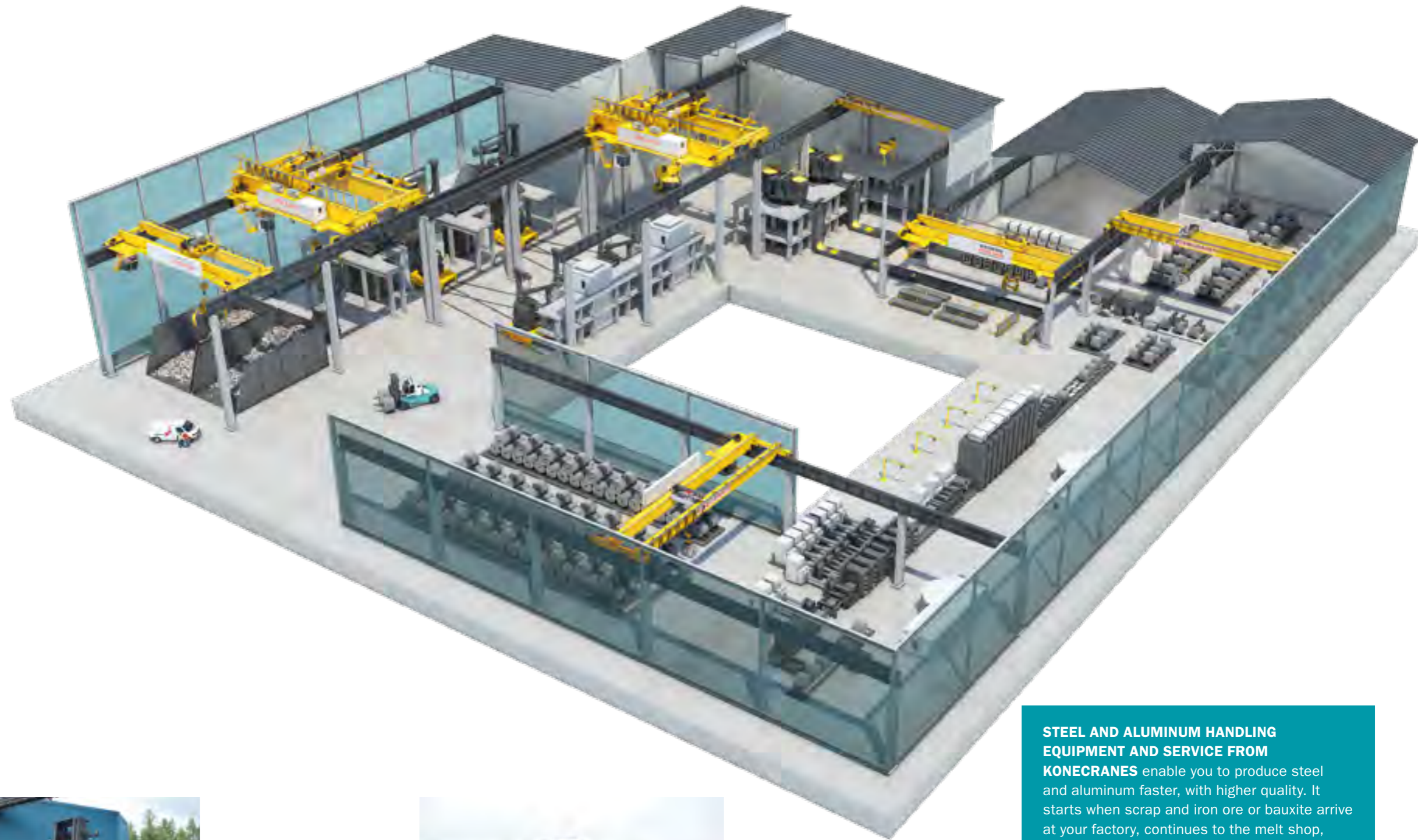

**STEEL AND ALUMINUM HANDLING EQUIPMENT AND SERVICE FROM KONECRANES** enable you to produce steel and aluminum faster, with higher quality. It starts when scrap and iron ore or bauxite arrive at your factory, continues to the melt shop, through casting and molding, and on to storage and shipping. Our technology contributes to a safer working environment, and improves process efficiency. The formula for our long-term success is to deliver all of the above, with the lowest possible Total Cost of Ownership.



**HEAVY-DUTY FORK LIFT TRUCK** with magnet. Powered by diesel generator. Special equipment for handling steel slabs.



**FORK LIFT TRUCK** handling aluminum slabs, bars and pipes.



**GRÄNGES SWEDEN AB** in Finspång, Sweden, operates a fleet of 10-ton Konecranes fork lift trucks in their warehouse and shipping operations. The trucks were designed specially to Gränges requirements.



**FORK LIFT TRUCK WITH MAGNET ATTACHMENT** for handling steel plates and slabs. Can be expanded to various widths 3–13 m.



**REACH STACKER FOR COMBINED CONTAINER AND STEEL SLAB HANDLING.** The hydraulic grab attachment lifts 1–3 slabs of up to 40 tons in one lift. A multi-function stacker.



**FORK LIFT TRUCK, CAPACITY 60 TONS,** handling hot steel slabs, blooms and billets with temperatures up to 800 degrees. Special attachment, carriage 11 m wide with 7 forks, to ensure that the steel does not bend during hot transport. Reinforced lifting equipment and heat protection. Capacities up to 60 tons.



**FORK LIFT TRUCK WITH TRIPLE COIL RAM** mounted on a fork shaft for handling steel wire. The quick-change fork shaft makes it possible to swap between various forks, coil rams and other attachments very quickly. Capacities from 10 to 33 tons.



**FORK LIFT TRUCK FOR HIGH-SPEED COIL HANDLING.** Kissing forks with rounded edges, lifting 4x16 or 2x32 ton coils in one lift. Reinforced lifting equipment and heat protection. Capacities 10–65 tons.



**FORK LIFT TRUCK WITH INTEGRAL 360-DEGREE ROTATOR** for scrap handling in containers with fork pockets. Capacities 10–60 tons.



**FORK LIFT TRUCK WITH FORKS MOUNTED ON A FORK SHAFT.** Quick-change fork shaft makes it possible to swap quickly between e.g. coil rams and lifting magnets.

# REACH STACKER ATTACHMENTS

For steel, aluminum and mining

You'll find your lifting solution in our complete range of attachments for reach stackers. What you see below is just a sample of what we offer.



**ELME INDUSTRIAL TOOL CARRIER SYSTEM**  
*Power Pile Slope*  
ELME industrial tool carrier system for connection tools. Strong and well-proven single beam spreader design, floating twistlock with hydraulic operation and mechanical safety locking.



**HYDRAULIC STEEL SLAB GRAB UNIT**  
with pairs of hydraulic lifting jaws. Various slab width combinations are available.



**LIFTING HOOK**  
for handling aluminium, steel and/or mining components and products.

# FORK LIFT TRUCK ATTACHMENTS

For steel, aluminum and mining

You'll find your lifting solution in our complete range of lifting masts, fork/carriage combinations, fork/shaft systems and attachments. What you see below is just a sample of what we offer.



**SINGLE COIL RAM WITH FORK SHAFT**



**DOUBLE COIL RAM WITH FORK SHAFT**



**FORK ROTATOR CARRIAGE**



**FORK SHAFT SYSTEM**  
*Pin-type*



**CARRIAGE WITH KISSING FORKS**

# MINING

**Do you have a thorny material handling problem in your mining operation? A heavy-duty lift truck from Konecranes, equipped with the right attachment, might be the solution.**

## Fork lift trucks and reach stackers

Konecranes fork lift trucks and reach stackers are used for general-purpose cargo handling in the mining sector.

The large tires of mining dump trucks and wheel loaders are handled by fork lift trucks with special tire clamp attachments. The tires are handled when they're unloaded from trucks or containers, when they're stored, and during tire and rim changing operations. Typical tire sizes are 2.5-5 m diameter (100-200"). Typical mining truck sizes are 15-42 tons.

The biggest tires are shipped in open-top containers or on flat racks. Reach stackers handling them need to have spreaders with folding legs for overheight cargo. The legs give an additional 1.6-2.1 m (63-83") of handling height for open-top containers or flat racks.

## Case: Newmont Ghana Gold

Newmont Ghana Gold, a subsidiary of U.S. company Newmont Mining Corporation and its construction partner Lycopodium Minerals Pty Ltd., used a Konecranes SMV 4531 TB5 reach stacker for container handling duties during the construction of a new gold mine in Akyem, Ghana. The machine has a lifting capacity of 45 tons and was sold through the Konecranes dealer for the country, Paterson Simons/Pasico. Newmont Ghana Gold chose a Konecranes reach stacker because it's the fastest and safest way to handle containers at the site.

Mine operators typically use mobile cranes for container handling, which they rarely view as a core mining activity. Usually, spare mobile cranes are drafted in for lifting when containers arrive onsite. Even with the best planning, this can have a detrimental effect on plant maintenance and consequently on operations. A reach stacker can handle containers with far more safety, speed and ease than mobile cranes – which can be dedicated to the work they are designed for.

Newmont Ghana Gold's reach stacker is not limited to handling containers. It has lifting eyes underneath the spreader, a standard feature, making it ideal for handling project cargo. The mine gets a flexible lifting machine with the typical stability advantages of a reach stacker.

Modern, large-scale mine operators and contractors can see the advantages of specialized lifting equipment. Container handling machines that have been sold to port terminals in large numbers are now finding their way to material handling sites where relatively few containers are handled. Reach stackers are the fastest and safest way to handle containers at sites such as the Akyem gold mine, where alternatives take up resources and time to manage effectively.



**FORK LIFT TRUCK WITH TIRE HANDLING ATTACHMENT**, handling tires from 2-5 m in diameter and loads weighing up to 20 tons. Truck models SMV 16-1200 C to 42-1200 C.



**REACH STACKER LIFTING CONTAINER HOUSE MODULES** using slings attached to the standard lifting eyes.



**FORK LIFT TRUCK** with tire handling attachment.



**HANDLING OF 20-45 FT CONTAINERS**



**REACH STACKER WITH FOLDABLE LEGS** handling big tires on flat racks.

**NEWMONT GHANA GOLD'S**  
new gold mine in Akyem, Ghana.



# GENERAL MANUFACTURING

The world of manufacturing ranges from the small two-person workshop to enormous factories producing tens of thousands of product units per day. Where do you fit in? What is your industry? What do you produce? Konecranes is the world's leading supplier of lifting equipment and service to manufacturing customers. Our lift trucks can give your logistical operations new power.

## Light manufacturing

For light manufacturing, we offer a range of overhead lifting systems that are adaptable to your production line and workstation design. Our product range includes chain hoists, jib cranes and workstation manipulators. It also includes lift trucks. If your shipping and receiving operation handles significant volumes of containers and miscellaneous cargo, we have an excellent lift truck for the job.

## Heavy manufacturing

If your heavy manufacturing operation doesn't fall within one of the industry segments portrayed in this book, contact us. What is the nature of the cargo you need to move? Have you considered a heavy-duty lift truck for the job? Is the truck attachment you need not available? Call us, let's discuss the case. We are the best in the world at figuring out how to handle heavy, awkward items with a lift truck.



**HANDLING 5-, 10- AND 20-FT SPECIAL TANK CONTAINERS** with fork pockets, on oil and gas frames, fork lift truck models SMV 10-600 C and 16-1200 C.



**FORK LIFT TRUCK WITH MULTIPLE MAST COMBINATIONS.** Duplex mast with or without free-lift. Triplex mast, several fork carriages and fork types available. Capacities 10-65 tons.



**HANDLING PRE-FABRICATED** office unit. Various mast and fork combinations possible.



**EXTRA-LARGE REACH STACKER WITH SLINGS** to lift various kinds of special things e.g. machinery, wind turbine components weighing up to 80 tons with a load center of 2500 mm.



**REACH STACKER LIFTING OVERHEIGHT FLAT RACKS** with slings. Seen here: loading turbines and generators onto river barges. Capacities up to 45 tons.



**FORK LIFT TRUCK FOR STEEL OR ALUMINUM MILLS** handling ingots, slabs and melting pots with special reinforcement and heat protection for hot metal handling. Capacities 10-65 tons.



**REACH STACKER WITH SPECIAL SLING ATTACHMENT** for lifting various things such as large cable drums, generators, turbines and special housings weighing up to 45 tons.

# PULP & PAPER, WOOD

**Konecranes has a relationship with the pulp, paper and wood industries that reaches back to the 1920s, when we started manufacturing Electric Overhead Travelling cranes. Our offering covers lifting equipment and service for every phase of production, and includes lift trucks with every special attachment needed.**

Konecranes serves the wood, pulp and paper industries with a complete portfolio of lifting equipment and services. Lift trucks are a very strong part of our offering for this industry, and we have decades of experience. We are also an experienced supplier of lift trucks to sawmills.

### Reducing paper roll damage

Working closely with leading pulp and paper companies, we have developed a unique system to improve the handling of paper rolls. It brings together fork lift trucks and technology used by the aircraft industry. A programmable microprocessor is at the heart of the system. Sensors collect key operating information such as tire pressure, engine temperature and RPM, transmission status, steering wheel angle, the tilt angle of the lifting mast, lifting height, load weight, hydraulic pressure, running hours and fuel level. The information is sent to the monitor display in the cabin.

The system reduces damage to the paper rolls. The auto-tilt function keeps the rolls in the vertical position. The truck is prevented from moving until the roll is off the ground. The paper clamp attachment opens automatically when the roll touches the ground. Simultaneously, the lowering motion stops, preventing friction of the clamp on the roll. Clamp pressure can be adjusted across three different levels, and it's monitored and maintained to within  $\pm 5$  bar of the programmed limit. The system is made for both single and double clamp handling.

### Off-the-shelf clamps

Konecranes fork lift trucks are equipped with automatic pressure sensing and reduction technology, so you can use off-the-shelf paper clamps. Different brands and makes can be used with the same truck thanks to our quick-change connection system.

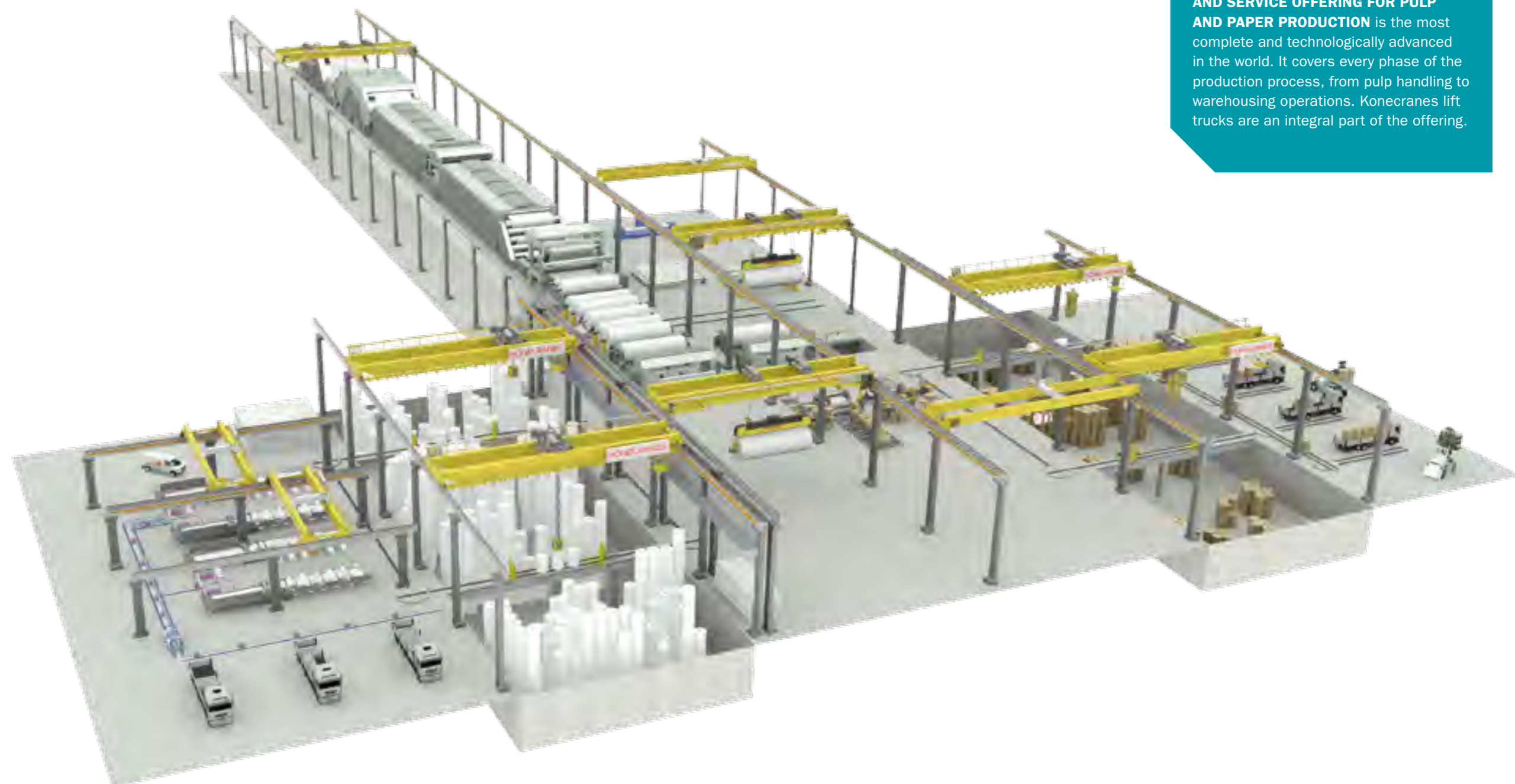

**THE KONECRANES LIFTING EQUIPMENT AND SERVICE OFFERING FOR PULP AND PAPER PRODUCTION** is the most complete and technologically advanced in the world. It covers every phase of the production process, from pulp handling to warehousing operations. Konecranes lift trucks are an integral part of the offering.



**FORK LIFT TRUCK WITH DOUBLE PAPER CLAMP** mounted on fork shaft. Lifts up to 6 reels across 2 rows in one lift. Seen here with a duplex free-lift mast, built low. Capacities 10–20 tons, optional rotator, bale clamp and tilt.



**FORK LIFT TRUCK WITH EXPANDABLE PAPER BALE ATTACHMENT** mounted on fork shaft for e.g. paper recycling operations. Lifts multiple bales in one lift. Capacities 10–20 tons, optional rotator, bale clamp, tilt.



**FORK LIFT TRUCK WORKING IN A SAWMILL**, lifting 2 to 4 wood packages at a time, 8–16 tons. Different attachment combinations available including special fork leveling carriages.



**RAUMA STEVEDORING OY, RAUMA, FINLAND.** The town of Rauma is a major port for paper exporting. Emptying of incoming trucks, warehousing operations, loading of Ro-Ro vessels and vessel side-loading.



**WOOD HANDLING.** We have decades of experience in the supply of fork lift trucks to sawmills, optimized for drier feeding, handling wood packs in warehouse operations and shipping finished goods.



**12-TON FORK LIFT TRUCK** moving sawn wood bundles at a sawmill.

# ATTACHMENTS

## For wood handling

What kind of wood product do you need to handle? We have a complete range of fork/carriage combinations, fork/shaft systems and attachments based on a quick-change system. We'll provide the right attachment for the work you need to do.



**FORK SHAFT SYSTEM**  
Pin-type



**FORK SHAFT SYSTEM**  
Hook type



**FORK AND CARRIAGE COMBINATION**  
Carriage with one leveling fork (up/down)  
for sensitive saw mill products

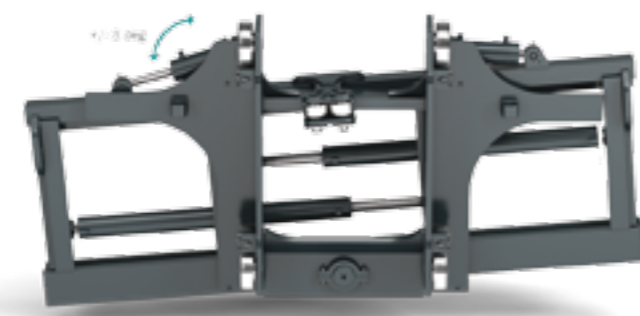

**CARRIAGE WITH CENTER LEVELING**  
Two forks for sensitive cargo

# ATTACHMENTS

## For pulp & paper handling



**PAPER ROLL CLAMP**  
With or without rotation, capacities 5 – 15 tons



**DOUBLE ROW PAPER ROLL CLAMP**  
2 – 6 rolls in one lift, capacities 5 – 15 tons



**EXPANDABLE PAPER ROLL AND PAPER BALE CLAMP**  
Capacities 5 – 15 tons



**MULTI BALE CLAMP**  
Capacities 5 – 15 tons

# AUTOMOTIVE

Automobile manufacturers and their subcontractors transport about 95% of their components in containers, swap bodies or trailers on trucks, trains and barges. Automobile manufacturers and the logistics companies working for them are some of the largest freight forwarders in the world. Konecranes meets the special needs of this industry with a complete range of lift trucks and attachments for truck, train and barge handling. We also supply a complete portfolio of cranes for automobile manufacturing.

## The cranes

A Konecranes CXT crane supplies the coils for unreeling, and a SMARTON® crane feeds the dies to the stamping line. Konecranes CLX chain hoists are a good choice for the workshops, and jib cranes and AirBalancers are ideal for sub-assembly workstations. Our XA crane and ATL Vertical Lifter combine to form a precision manipulator with a customized gripping unit specially made for each part of the automobile. Available with our CXT and SMARTON® cranes, our Smart Features such as Sway Control, Microspeed and Target Positioning give you unprecedented control over your load handling.

## The lift trucks

Your load handling control extends to your shipping and receiving operations with lift trucks. We offer fork lift trucks and reach stackers that we can adapt to your special material handling applications in various ways.

We provide fork lift trucks optimized for handling the steel coils and pre-cut steel plates that are used in stamping presses to make auto body components. These lift trucks can also handle the stamping tools used in the presses, weighing anywhere from 30–60 tons.

The scrap metal produced as a by-product of the auto body stamping process is usually handled in containers by fork lift trucks or reach stackers. We provide these lift trucks, optimized for this role.

After painting, the finished components are stored and delivered to the assembly plant by road, rail or river. Arriving at the assembly plant, they are handled by fork lift trucks or reach stackers. Our lift trucks can be optimized for this role as well.

**IMPORTANT AUTOMOBILE MANUFACTURERS RELY** on Konecranes lifting equipment and service. We understand the special needs of this industry for heavy load handling, short cycle times, high productivity and safety.

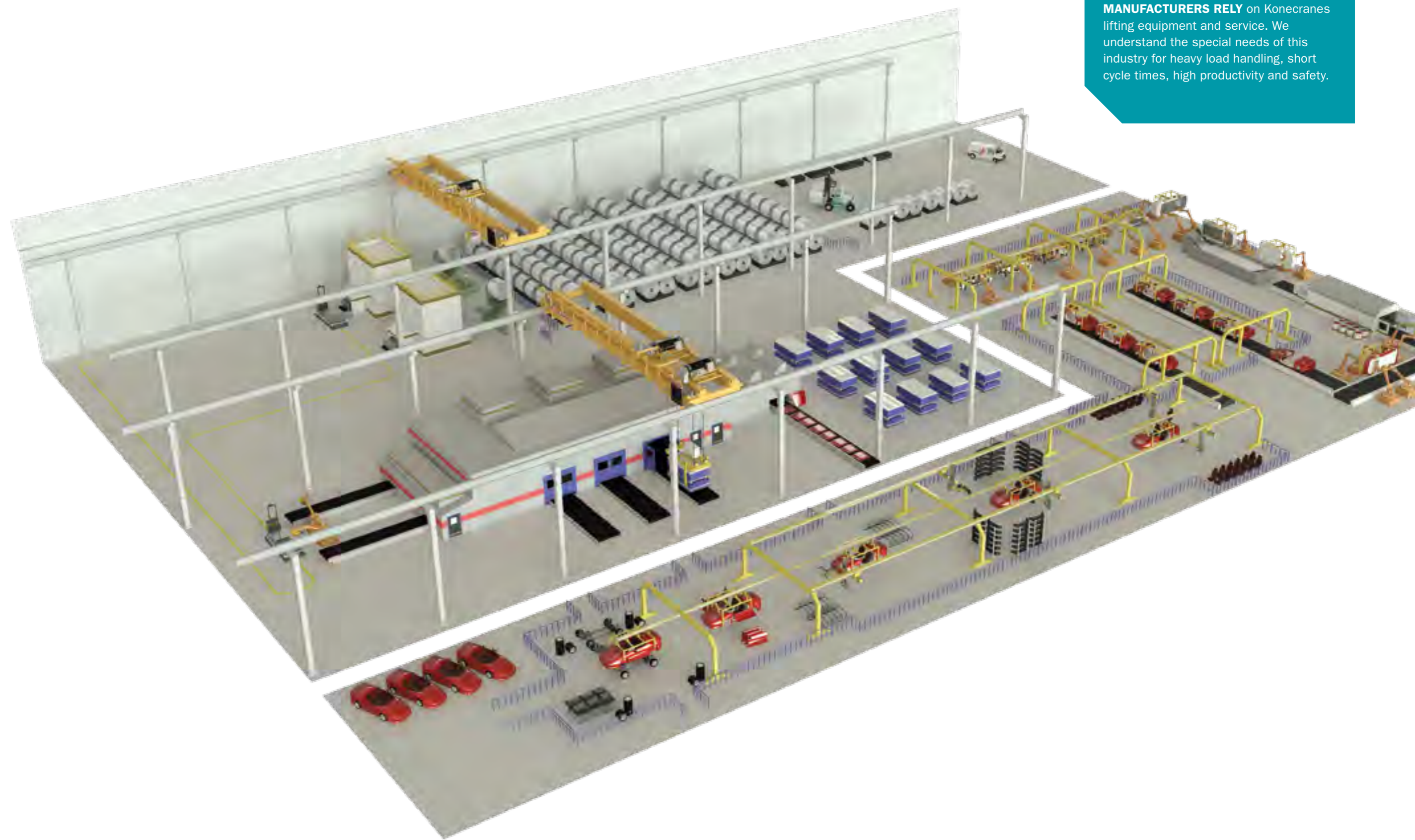

**REACH STACKER FOR AUTOMOTIVE LOGISTIC OPERATIONS.** Various models for handling 20–45 ft containers, auto body parts, engines, transmissions and other automotive components.



**REACH STACKER AND SPREADER WITH OVERHEIGHT FOLDING LEGS** for handling containers with open tops for overheight cargo.



**FORK LIFT TRUCK HANDLING CONTAINERS LOADED WITH AUTOMOTIVE COMPONENTS** including engines, transmissions, etc. Capacities 16–42 tons.



**FORK LIFT TRUCK WITH FREE-LIFT MAST,** fork-shaft system and single coil ram, handling automotive steel and aluminum coils.



**FORK LIFT TRUCK WITH FORK-MOUNTED MAGNET,** handling 1–20 mm steel plates.



**INDUSTRIAL CRANE** lifting stamping press tools.

# WIND POWER

Material handling plays an important role during the manufacturing of wind turbines, which comprise a number of uniquely shaped, heavy components. It is also very important during the delivery and erection phases. Konecranes offers reach stackers and fork lift trucks optimized for the special handling needs of the wind power industry.

Heavy components need to be handled at various phases of the manufacture, delivery and erection of a wind turbine. The nacelle, tower sections and hub are extremely heavy, very large and prone to damage. Transportation costs can account for 10–25% of the overall project cost of a wind turbine. Konecranes has the experience, know-how and product range to help you keep transportation costs down and damage to a minimum. We offer fork lift trucks and reach stackers that lift 10–80 tons and all the special attachments needed.

## Tripods, below sea-level

The foundations of offshore wind turbines are “tripods”: huge, one-piece objects welded from steel weighing 800–1200 tons apiece. The first step in tripod construction consists of welding together large steel plates, forming “mid-size” sections weighing 25–100 tons. These sections are then welded together in turn to form the finished tripod.

Konecranes double fork lift trucks and/or reach stackers are ideal for handling the 25–100 ton mid-size sections during the tripod manufacturing process. A single Konecranes fork lift truck or reach stacker can lift 60–80 tons. In tandem lifting, 120–160 tons can be lifted. The “mid-size” sections are lifted and shifted many times as they’re welded and painted, before leaving the factory.

## Tower sections

Large Konecranes fork lift trucks and reach stackers are used in the production of the tower sections, which can weigh anywhere from 30 to 100 tons. Our trucks lift, handle and sort the steel plates that are rolled and welded together to form the tower sections. Our reach stackers, equipped with a crane hook, can lift 50–80 tons up to 15 m high, with a reach stroke of 7 m.

## Blades

A wind turbine normally has three blades, each 25–85 m long and weighing 10–20 tons. They can be handled with Konecranes reach stackers equipped with sling attachments, or Konecranes fork lift trucks. They are often stored in multiple flat racks. The blades are handled many times before they leave the factory, from casting to painting and everything in between.

## Nacelles

The normal nacelle housing ranges in size from 20–40 feet but can take various shapes. The nacelle contains the blade fixtures, the generator unit, the transmission, the bearings and bearing housing, the electronics and the controls. These components, weighing 5–50 tons apiece, are assembled at the nacelle assembly plant. The finished nacelle can weigh anywhere from 50–250 tons and will often be delivered in pieces. Konecranes reach stackers, equipped with special attachments, are ideal for material handling during this process.



**KONECRANES REACH STACKERS, LIFTING CAPACITIES 45/80 TONS,** seen here handling long wind turbine blades in Germany.



**FORK LIFT TRUCK BUILT TO HANDLE LONG WIND BLADES** from 20–65 m. Capacities 10–33 tons.



**FORK LIFT TRUCK CUSTOMIZED FOR WIND POWER HANDLING** of large, thick steel plates for tower section manufacturing. Very strong lifting equipment and reinforcement. Capacities 25–65 tons.



**FORK LIFT TRUCK CUSTOMIZED FOR WIND POWER HANDLING,** from steel plates to tower sections to generator housings and windmill blades. Capacities 10–65 tons.



- 1 Tower
- 2 Generator housing
- 3 Blade hub
- 4 Blade
- 5 Service and maintenance crane
- 6 Konecranes service crane for lifting spare parts and tools during maintenance and repairs



**A KONECRANES SMV 32-1200 B RO-RO** fork lift truck handling “tripod” foundation elements and machine components. Its load-sensing hydraulics make it ideal for this job. With its low height of 2.95 m, load carrying capacity of up to 32 tons, and excellent acceleration, it is also a top performer in its main job – load handling aboard Ro-Ro ships.



# ATTACHMENTS AND HANDLING METHODS

## For the wind power industry

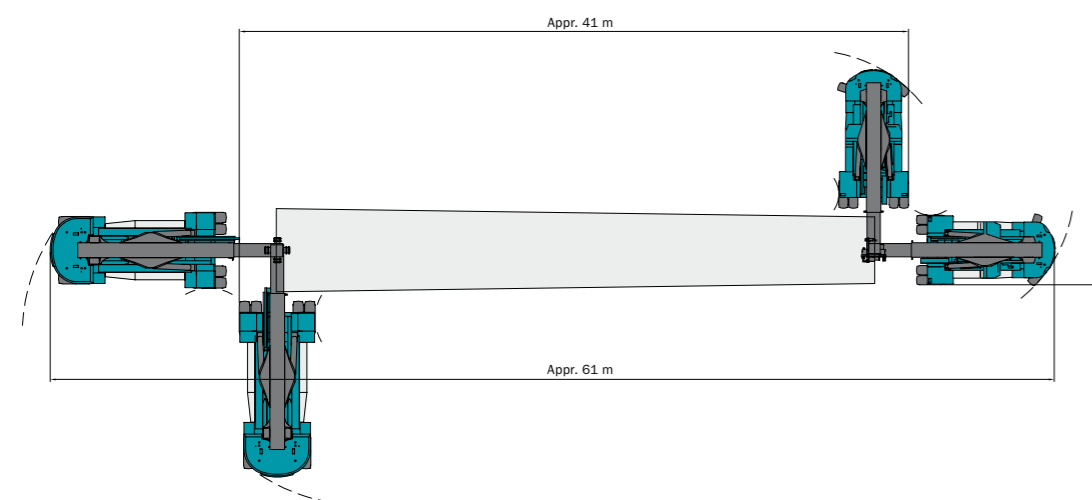
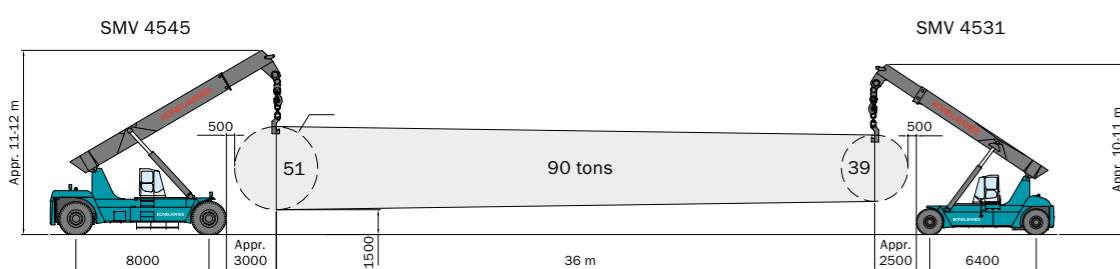

**TWO KONECRANES REACH STACKERS OR FORK LIFT TRUCKS** can be used to lift and handle tower sections, weighing anywhere from 50 to 160 tons, during manufacturing and intermediate storage and transportation.

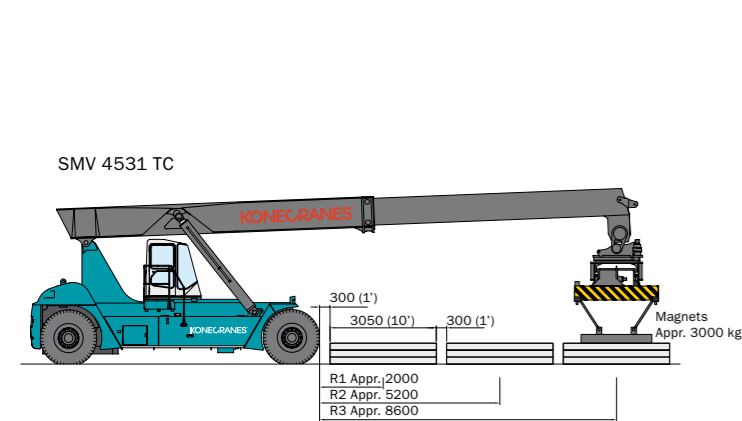

**KONECRANES REACH STACKERS AND FORK LIFT TRUCKS** can be equipped with a magnet lifting attachment for handling steel plates, semi-finished sections and finished components during tower manufacturing. These loads can be lifted, moved in and out, side-shifted and rotated as needed with the joystick in the cabin.

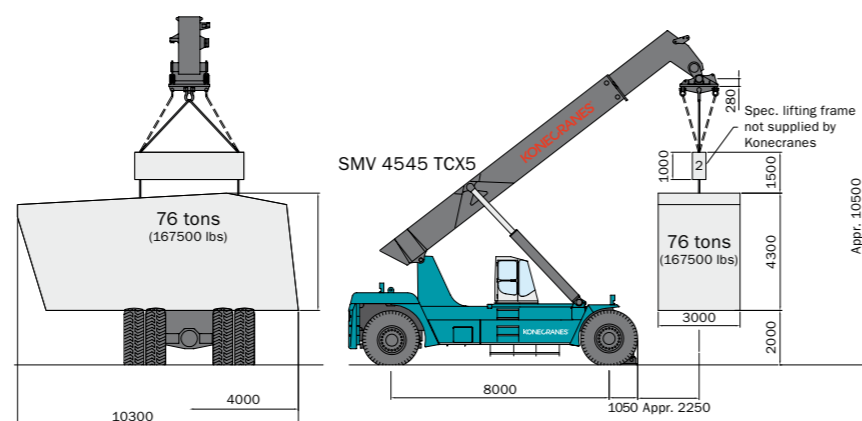

**REACH STACKER WITH A LIFTING BEAM AND SLING** for handling nacelles weighing 75–100 tons.

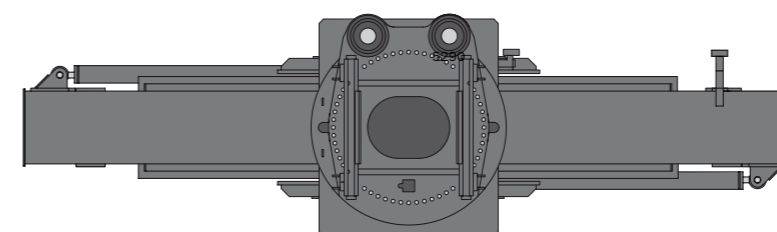
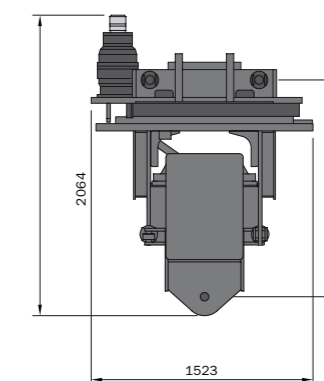
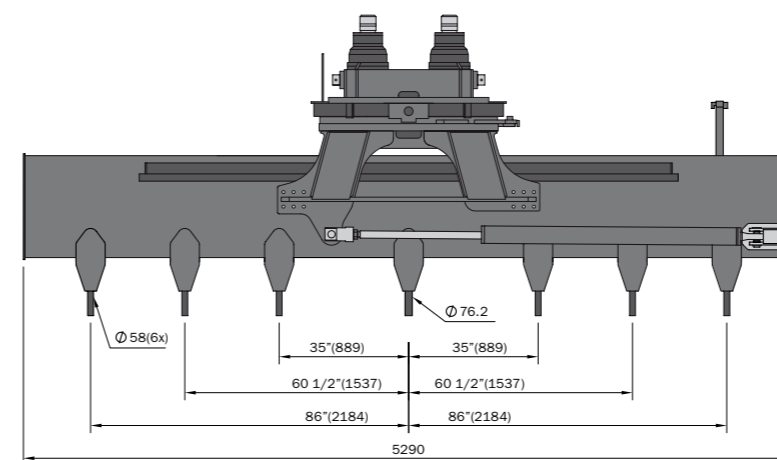

**REACH STACKER LIFTING BEAM** and sling for handling nacelles weighing 75–100 tons.

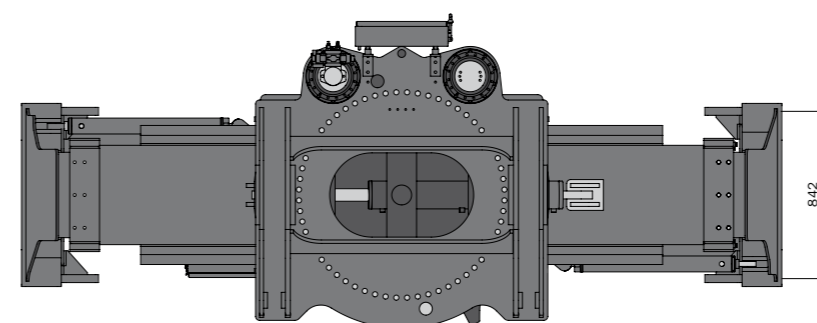
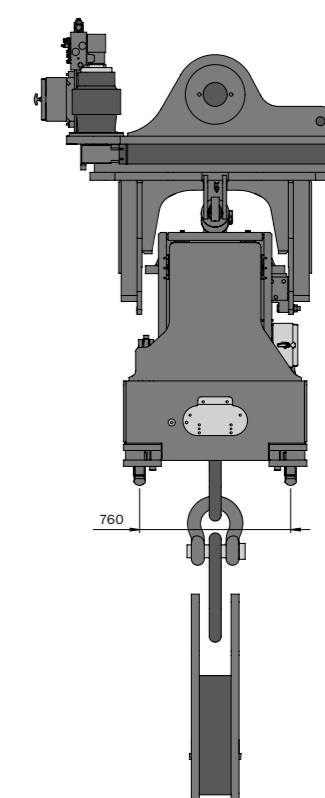
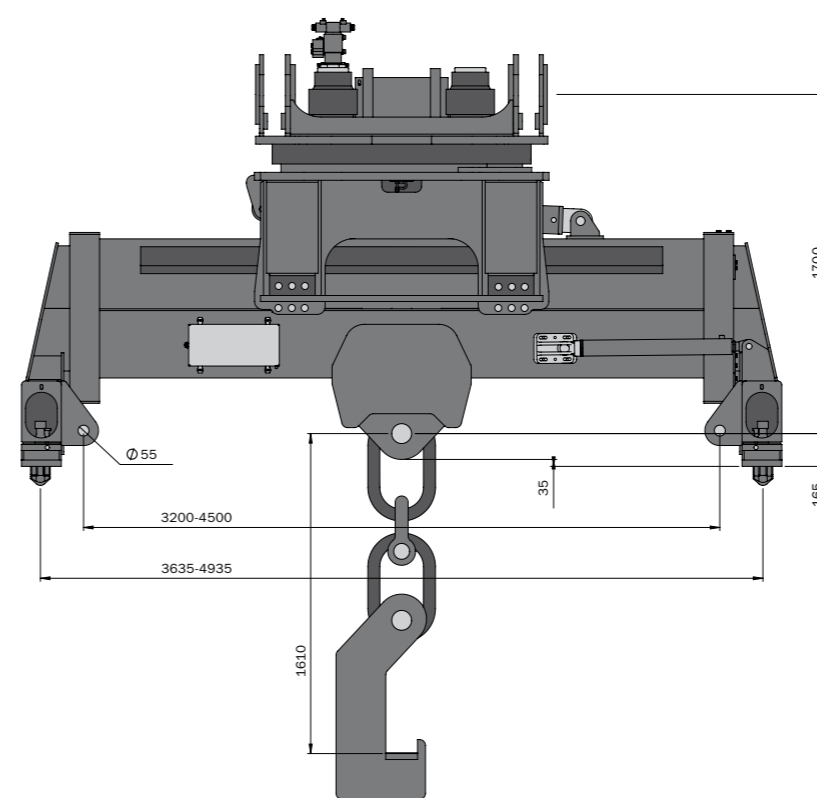

**SPECIAL ATTACHMENT** for lifting and handling tower segments.

# OIL & GAS

**Konecranes is an important supplier of lifting equipment to the oil and gas industry, with special knowledge of the lifting requirements involved in many parts of the production process.**

Konecranes, under the Konecranes and STAHL brands, is the world's leading provider of explosion-protected hoist and crane technology. Our references cover explosion-protected cranes for refineries, special lifting systems for drilling rigs, and wire rope hoists for natural gas liquefaction (LNG) plants. The industry has very stringent safety requirements, and we fulfill them with state-of-the-art safety features.

### Explosion-protected crane technology

Konecranes, under the STAHL brand, has over 130 years of experience with explosion-protected lifting technology. STAHL SH ex and AS 7 ex explosion-protected wire rope hoists meet EC product directive 94/9/EC (ATEX 95) and international IECEx regulations. These adaptable wire rope hoists have a modular construction and a load capacity range of 1,000 kg to 160,000 kg.

The ST ex explosion-protected chain hoists are available in 13 load capacity ranges from 125 kg to 6,300 kg. They can be used as stationary hoists with a suspension hook or eye, rigid suspension or an electric trolley. They are particularly suitable for rugged oil & gas industry use.

### LNG hoists for LNG plants, trains and terminals

Konecranes provides LNG hoists under the STAHL brand, developed specifically for the maintenance of LNG plants. Thanks to their high-quality components and robust design, they are specially adapted for the rugged climates of coastal areas. Our LNG wire rope hoists feature a completely redundant design: two hoists, two brakes, two gears and two ropes ensure that in the – unlikely – event of a rope breaking or a malfunction, hoisting can continue without interruption, and without damaging the valuable pump or other parts of the LNG plant. These hoists conform with ATEX and IECEx directives and do not present an explosion hazard even if natural gas should evaporate.

### Lift trucks for outdoor material handling

Konecranes offers lift trucks for a wide range of oil & gas material handling applications along with a wide range of special attachments.



**HANDLING 5-, 10- AND 20-FT SPECIAL TANK CONTAINERS** with fork pockets, on oil & gas frames, fork lift truck models SMV 10-600 C and 16-1200 C.



**HANDLING BIG PIPES, VARIOUS SIZES AND WEIGHTS** with a regular reach stacker equipped with a pipe clamp attachment. One to five pipes can be lifted at a time, weighing 1–30 tons.



**REACH STACKER LIFTING SPECIAL TANKS** and offshore equipment.



**ONE BIG PIPE OR MULTIPLE SMALLER PIPES** can be handled with a hydraulic pipe clamp attachment. Capacities 10–45 tons.



**PIPE-HANDLING FORK LIFT TRUCK WITH A HYDRAULIC PIPE CLAMP** can safely handle long pipes. Capacities 10–45 tons.



**KONECRANES SUPPLIES SPECIAL COKER CRANES** for clearing coke pits at petroleum refineries. This type of crane is always designed for the specific customer, but will usually have a lifting capacity of 30+ tons and a bucket with 15+ m<sup>3</sup> capacity. The crane places the coke on a conveyor that carries it to be prepared for transport by rail or barge. Semi-automated controls, using pre-programmed destinations, are engaged during different parts of the process. The load control programs are designed to make the crane last longer by reducing stresses on the steel structure.

# NUCLEAR

**Konecranes is the leading global supplier of lifting equipment for the nuclear power industry. With almost a half century of nuclear experience, and over 500 locations worldwide, Konecranes has the knowledge and resources to ensure the success of your project. As a full service supplier, we provide every type of lifting equipment required for the nuclear industry including a complete range of heavy-duty lift trucks.**

Konecranes offers reach stackers and fork lift trucks for various applications in the nuclear power production process. For example, we offer reach stackers that can handle 45-ton overpacks. We offer heavy-duty fork lift trucks that handle general cargo up to 65 tons, and standard 20-ft containers. These lift trucks can also handle longer containers from the end with special end-lift attachments. The best way to illustrate what we can do for your industry is to give an example:

## Magnox North, Trawsfynydd, Wales

Konecranes has supplied a special reach stacker to handle 45-ton concrete overpacks containing intermediate level nuclear waste (ILW) for Magnox North at its Trawsfynydd site in Wales. The machine will move the ILW into a purpose-built store that will contain the waste until a national repository becomes available.

Konecranes, in cooperation with spreader supplier ELME, designed a special attachment to handle the specially-built 2.5 m<sup>2</sup> overpacks that encase a heavy-duty stainless steel box in which the waste is transported. Critical safety factors include the control of the vertical lift, the distance of the driver from the box of ILW and a number of bespoke recovery procedures.

Doug Barber, ILW Store Project Lead at Trawsfynydd, commented: "This is an unusual handling application in that the number of lifts is small, but the operation needs to meet the highest levels of environmental, security and safety standards. The UK nuclear industry is one of the toughest industrial regimes in the world. We needed absolute control over the vertical lift, a machine that could perform accurately under extremely slow conditions as well as a provision for total manual override."

Magnox North personnel were involved throughout the design, manufacturing and testing process that saw numerous visits to the Konecranes production facility in Markaryd, Sweden. An essential pre-requisite of the supply contract was adherence to the strict quality demands of the nuclear industry.

The specially designed attachment has elongated twistlocks that produce a synchronized arc and extension as the boom moves in, ensuring a permanent vertical lift. The machine has also been programmed with special logic and load curve characteristics to handle the waste load versus the lighter stillage utilized for handling drums, thereby ensuring that each load is handled with the same care and attention.

"This is the first time we have been asked how slowly our reach stacker could lift and lower, or how much air space there is between the driver and the load," said Anders Nilsson, Technical Director, Konecranes Lift Trucks. "Both parameters are critical for safe operation at Magnox. In addition, we were asked to provide an override system to raise the boom manually in the event of truck power failure. A second electronic override system was also specified to ensure the machine can only travel empty when the boom is at a pre-determined height to eliminate accidental damage to the extended twistlocks."



**KONECRANES HAS SUPPLIED A SPECIAL REACH STACKER** to handle 45-ton concrete overpacks containing intermediate level nuclear waste (ILW) for Magnox North at its Trawsfynydd site in Wales.



**FORK LIFT TRUCK** customized to handle uranium oxide.



**KONECRANES TURBINE HALL CRANE.** We have supplied over 100 large turbine hall cranes to nuclear power plants, and hundreds of cranes of this type to non-nuclear power plants. Our turbine hall cranes include many special design features that improve performance such as on-board diagnostics, precise load positioning and remote operator controls.



**KONECRANES HAS OVER 50 YEARS OF NUCLEAR INDUSTRY EXPERIENCE.**  
We supply a complete range of heavy-duty, long-span nuclear polar cranes, nuclear fuel transfer equipment, and many other kinds of nuclear lifting equipment. We comply with stringent nuclear regulatory requirements, and are a member of key regulatory and advisory groups such as the ASME NOG-1 committee, which sets standards for the design of lifting equipment used by the nuclear industry.

# CONCRETE, BRICK AND ROCK

**We offer tough and durable fork lift trucks for handling concrete, brick and rock in quarries, concrete and brick factories, intermediate shipping sites and ports.**

Strength, power and reliability are the key words for fork lift trucks handling concrete, brick and rock without sacrificing fuel efficiency or safety. Konecranes fork lift trucks are a popular choice for this job. We offer a complete range of fork lift trucks, lifting masts and fork-shaft systems for these applications – often with a high degree of customization.

Lift trucks with special adaptations are needed during the fabrication of concrete sections and tubular components. These can include special masts, wider fork carriages, multiple forks and heavy-duty reinforcements needed for sensitive concrete cargo. To lift and handle bricks in packages, the trucks will often have a single or double brick clamp with an integral mounting. The toughest job is handling marble blocks, often very large and weighing 30–40 tons apiece. For this the lift trucks are reinforced and specially adapted to the customer's individual requirements.

**LOADING AND UNLOADING OF STONE BLOCKS**, e.g. marble or granite, into containers and onto trucks, SMV 25-1200 C and 33-1200 C.



**HANDLING BIG, ROUGH AND HEAVY MARBLE BLOCKS**, 10–40 tons, loading and unloading ships, many heavy-duty options for the lifting equipment, SMV 42-1200 C and 52-1200 C.



**CONCRETE PRODUCTION** of various kinds. Loading trucks, extra-wide carriage (7 m) with 4 forks and side-mounted cabin for extra visibility, SMV 37-1200 C and 50-1200 C.



**BRICK PRODUCTION**, handling of single and double brick packages with integral hydraulic gripper. Capacities 10–20 tons.



**HANDLING OF CONCRETE SECTIONS**, fork lift truck with wider carriage, long forks, elevated cabin and reinforced lifting equipment, SMV 25-1200 C and 33-1200 C.



**Big marble blocks, 5–30 tons**, loading and unloading trucks and containers, SMV 25-1200 C and 33-1200 C.



# WASTE-TO-ENERGY AND BIOMASS

Turning waste or biofuel into energy is a long, multi-stage process. Many tasks need to be managed simultaneously to ensure the plant operates at peak efficiency. Just one piece of faulty equipment can cause the whole process to stop. Konecranes provides fast, safe, and reliable lifting solutions designed for this special environment including lift trucks with special attachments.

We offer a range of tailored cranes to fit your specific applications. For example, get a waste handling crane to pile and mix waste in the bunker and load it into the feeding hopper. Use a slag handling crane to load slag into disposal trucks. We provide these cranes with the special grabbing devices needed, such as orange peel or clamshell-type buckets. We can also provide a magnet to remove ferrous metal from the slag.

Our ability to customize extends to our lift truck offering for the waste-to-energy and biomass industries. We offer a complete range of fork lift trucks, reach stackers and container lift trucks, with all the special attachments needed. Waste is usually shipped in containers, typically 20-ft long and weighing 12–18 tons. Biomass is typically handled in 20-ft and 40-ft containers weighing 15–25 tons.

To empty these containers, Konecranes offers fork lift trucks with a 180 or 360-degree rotation unit, or reach stackers with 45-degree side-tilt. Waste and biomass containers are usually not very heavy, so medium-sized Konecranes fork lift trucks and reach stackers with the needed attachments are an excellent solution. Our medium-sized fork lifts and reach stackers are very compact with a low Total Cost of Ownership.



**KONECRANES HAS OVER 50 YEARS OF EXPERIENCE IN WASTE HANDLING.** We offer intelligent crane technology including anti-collision systems, sway control and a wide array of automation options. Lift trucks are an integral part of our offering.



**FORK LIFT TRUCK WITH 360 DEGREE INTEGRAL ROTATOR** for waste-to-energy and biomass handling. Capacities 10–25 tons.



**REACH STACKER FOR EMPTY & SEMI-LADEN CONTAINER HANDLING**, stacking up to 3 or 6 containers high and 10 or 25 tons in the first row. Very efficient operation: the reach stacker can rotate the containers 300 degrees.



**WASTE IS HANDLED MAINLY IN 20-FT CONTAINERS** that are transported by road, rail or water. They can be handled by fork lift trucks, laden container lift trucks (seen here) or reach stackers. Waste containers weigh from 15–25 tons.



**FORK LIFT TRUCK WITH 360 DEGREE INTEGRAL ROTATOR** for biomass and waste-to-energy handling. Capacities 33–45 tons.



**LADEN CONTAINER LIFT TRUCK** for waste-to-energy and biomass container handling. Capacities 25–45 tons.

# CUSTOMIZED SOLUTIONS

You might have a material handling problem that seems unsolvable. Could it be solved by a heavy-duty lift truck? Have a look at what we've done for customers that had very special material handling problems.

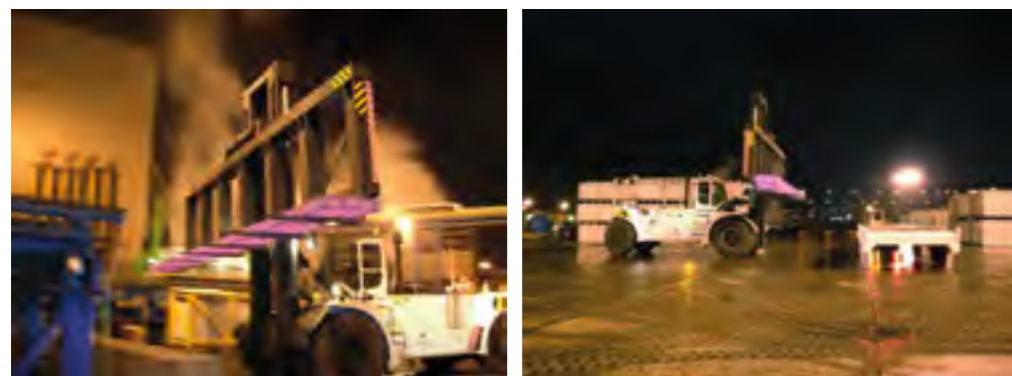

**HIGHLY SPECIALIZED FORK LIFT TRUCKS** (18–60 tons) for handling hot and cold steel slabs, blooms and billets. Equipped with 10 m wide carriage with 7 forks, hydraulic genset for lifting magnets and hydraulic bloom grab. Operated by the TATA Steel Group in the UK.



**SMV 32-1200 B FORK LIFT TRUCK** owned by SAM Montereau, a steel company in France. Adapted for steel wire handling: triple coil ram (integral) attachment, raised cabin (+400 mm), 1 extra step on each side of the cab.



**SMV 12-600 B FORK LIFT TRUCK** owned by dealer Suffel Fördertechnik GmbH, Germany. Double pallet handling with four forks for dairy and brewery products.



**SMV 10-1200 FORK LIFT TRUCK** owned by Heléns, a tubing/piping warehousing company in Halmstad, Sweden. Specially equipped for handling long steel pipes: extra big tilt for long goods of ±30 degrees.

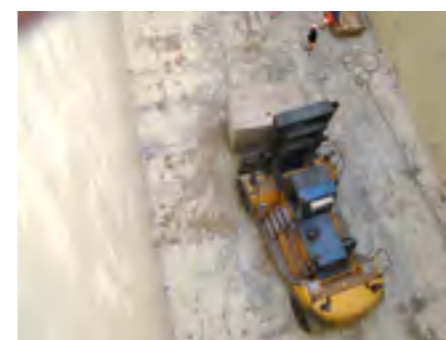

**SMV 25/42-1200 FORK LIFT TRUCKS**, Port of Carrara, Italy. Compact lift trucks for heavy loads in a tight and very tough environment, optimized for handling the world-famous marble of Carrara.



**SMV 45-1200 FORK LIFT TRUCK** working in a mining application, Valtasiirto Oy, Finland. A multi-functional truck with forks, fork rotator (360 degrees) and a container spreader.



**SMV 4542 TBX4 BH REACH STACKER**, Terminal de Seine, France. Container barge handling. Equipped with a vertically movable cabin and ELME 817 spreader with overheight folding legs.



**SPECIAL REACH STACKER**. Alpro, food and drink products, Wevelgem, Belgium. This customer had very special requirements, needing a barge handler but having very serious limitations on ground pressure. Alpro is very strongly focused on safety and green technology. This was one of the first lift trucks with AdBlue technology delivered to Belgium. Due to the limitations on ground pressure, we delivered an SMV 4542 TBX4 BH reach stacker with a 7500 mm wheelbase and a larger than standard jack plate to reduce ground pressure. It's equipped with a heavy-duty boom for barge handling. It has many safety extras: reverse distance control, laser-based distance measuring system, lots of extra lamps, and so on. The customer is very satisfied with the truck and the advice and support given during the purchasing procedure. We were the only manufacturer that could supply this kind of custom-built machine.



**SMV 4537 TBX6 "NEW COMBINATION" REACH STACKER**. Faroe Islands, owned by Eimskip, the Icelandic Steamship Company. This reach stacker can handle tank containers up to 14 tons into the 4th container row at load center 8.75 m. It lifts 6 high in the 1st row, capacities 45-40-27-14 tons (with jacks) for rows 1-to-4. We mounted a boom designed for a larger reach stacker on this small truck body in order to meet the customer's requirements.

## WHY CHOOSE KONECRANES?

**KONECRANES IS ON A MISSION** to provide you with the lowest Total Cost of Ownership of heavy-duty lift trucks. But the value we provide is not merely economic. We are constantly pushing the boundaries of lift truck technology, industrial design and after-sales support. Productivity, eco-efficiency and safety are built into everything we do. Meanwhile, we are carrying forward the world's richest tradition of heavy-duty lift truck craftsmanship. We make lift trucks with heart.

**Konecranes is a world-leading group of Lifting Businesses™, serving a broad range of customers, including manufacturing and process industries, shipyards, ports and terminals. Konecranes provides productivity-enhancing lifting solutions as well as services for lifting equipment and machine tools of all makes.**

